

The FIRSTLINE UPS
25KVA, 30KVA, AND 37.5KVA

User's Manual



301 Gaddis Boulevard • Dayton, Ohio 45403
U.S. Toll Free 866-261-1191
(937) 253-1191 • Fax: (937) 253-1723
Web site: www.stacoenergy.com

Before Installing the UPS:

- Read all safety and installation instructions.
- Make sure that the UPS is the correct model for your application.
- Verify that the available power source matches the input rating of the UPS. Unless the UPS is in the tall cabinet and is equipped with a transformer option, the source should be 120 volts line to neutral, three phase, ABC sequence, with a grounded neutral.

Before starting the UPS:

- Read all safety and operating instructions.
- Verify that the UPS is installed in a clean, temperature controlled area.
- If the UPS is installed at an altitude above 1000 meters, the output load capability must be derated by 1% for each 100 meters above 1000 meters.
- Verify that the installation includes an input breaker of the proper rating.
- Verify that the wiring is correct and that all connections are neat and tight.
- Verify that the internal batteries have been connected.
- If an optional Extended Run Time Battery Cabinet is present, verify that it is equipped with the optional breaker or that an external breaker has been provided as part of the installation. The battery breaker should be closed before the UPS is started.
- Make sure that single phase loads are fairly evenly distributed across the three output phases. Balanced operation maximizes efficiency and reliability. (Check the individual output phase currents when the UPS is operating)

.

CONTENTS

Section 1	1
Introduction.....	1
FirstLine UPS Part Number System	2
Battery Option.....	2
Accessories	3
Section 2	4
Safety Warnings	4
Section 3	6
UPS Setup.....	6
Inspecting The Equipment	6
Floor Loading.....	6
Clearances	6
Unloading the Cabinet(s)	7
Placing The Cabinet	10
Section 4	11
Electrical Installation	11
Wiring Preparation	11
Wiring Installation	13
Wiring Specifications and Diagrams	15
Removing and Replacing The Front Panel	18
Connect The Internal Battery	18
Section 5	20
Communication.....	20
Customer Interface	20
Section 6	22
Operation.....	22
Display Functions	24
Section 7	25
Initial Start Up	25
Normal Operation	25
Manual Transfer to Bypass.....	26
Manual Transfer to Inverter	26
External Bypass Arrangement	26
Automatic Transfer To Bypass	27
Automatic Transfer To Inverter	27
OverLoad.....	28
Inverter.....	28
Bypass	28
Rectifier	28
Section 8	29
Battery Removal, Installation, and Service	29
Polarity Verification Procedure	32
Stopping the Rectifier in the UPS	33
UPS Maintenance.....	34
Battery Fuse Replacement	35
Section 9	37
Optional FirstLine Extended Run Time Battery Cabinet	37
Section 10	38
FirstLine UPS Technical Specifications	38

Table 1-Part Numbering System	2
Table 2-Symbols	4
Table 3-Model Floor Loadings.....	6
Table 4-Input/Output Terminal	13
Table 5-Ground Lugs	13
Table 6-FirstLine UPS 10-20kVA Current Requirements	14
Table 7-Terminal Block Wiring	16
Table 8-Torque Values for TB1, 2, 3, 4	21
Table 9-Indicator Status and Description	23
Table 10-Menu Map for Display Functions.....	24
Figure 1-The FirstLine UPS 25-37.5kVA	1
Figure 2-UPS on pallet.....	7
Figure 3-Shipping Bracket.....	8
Figure 4-Lifting fork area	9
Figure 5-Leveling foot being adjusted down to the floor	10
Figure 6-Bottom View	12
Figure 7-Terminal Blocks	13
Figure 8-UPS Wiring-Single Line Diagram	17
Figure 9-Removing the UPS Front Panel.....	18
Figure 10-Internal Battery.....	19
Figure 11-Communication Options and Control Terminals.....	20
Figure 12-TB3	21
Figure 13-TB4	21
Figure 14-FirstLine Front Panel Display and Control Module.....	22
Figure 15-Battery Tray	29
Figure 16-Battery Tray	30
Figure 17-Battery Installation	31
Figure 18-The FirstLine Extended Run Time Battery Cabinet.....	37

SECTION 1

Introduction

The FirstLine uninterruptible power supply (UPS) is a true online, double-conversion, three-phase system that can be used to prevent loss of valuable electronic information and minimize equipment downtime. It is ideal for protecting essential information technology and electrical engineering infrastructure in corporate, telecom, health care, banking, and industrial applications.

The FirstLine UPS continually monitors incoming electrical power and removes surges, spikes, sags, and other irregularities that are inherent in commercial utility power. Working with a building's electrical systems, the UPS supplies clean, consistent power that sensitive electronic equipment requires for reliable operation. During brownouts, blackouts, and other power interruptions, batteries provide emergency power to safeguard operation.

Figure 1 shows two versions available: Short cabinet for compact 208/208 or 220/220 requirements and the tall cabinet for extended run time built in, or 480V I/O.

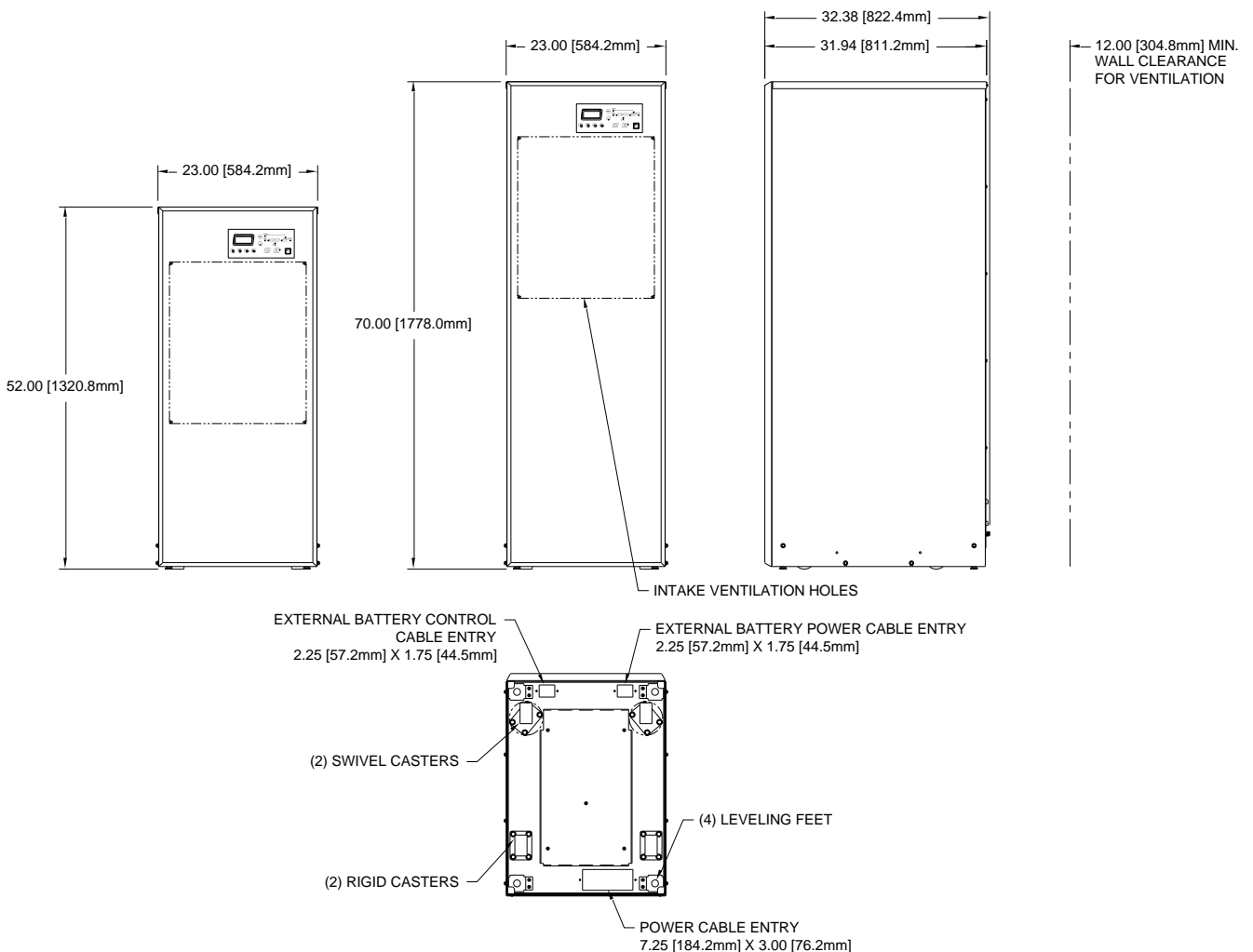

Figure 1-The FirstLine UPS 25-37.5kVA

FirstLine UPS Part Number System

Table 1-Part Numbering System

kVA	Input Voltage	Output Voltage	Run Time (min.)	Cabinet	Full Part Number		
					Basic Part No.	Battery Option	Other Options
25	208Y/120	208Y/120	11	Short	FLU-25S-20	-1	
	480	208Y/120	11	Tall	FLU-25T-42	-1	-I
	480	480Y/277	11	Tall	FLU-25T-44	-1	-I
	208Y/120	208Y/120	28	Tall	FLU-25T-20	-2	
	208Y/120	208Y/120	11	Tall	FLU-25T-20	-1	-I
	220Y/127	220Y/127	11	Short	FLU-25S-22	-1	
	220Y/127	220Y/127	31	Tall	FLU-25T-22	-2	
	30	208Y/120	208Y/120	8	Short	FLU-130S-20	-1
480		208Y/120	8	Tall	FLU-30T-42	-1	-I
480		480Y/277	8	Tall	FLU-30T-44	-1	-I
208Y/120		208Y/120	22	Tall	FLU-30T-20	-2	
208Y/120		208Y/120	8	Tall	FLU-30T-20	-1	-I
220Y/127		220Y/127	11	Short	FLU-30S-22	-1	
220Y/127		220Y/127	24	Tall	FLU-30T-22	-2	
37.5		208Y/120	208Y/120	5	Short	FLU-37S-20	-1
	480	208Y/120	5	Tall	FLU-37T-42	-1	-I
	480	480Y/277	5	Tall	FLU-37T-44	-1	-I
	208Y/120	208Y/120	16	Tall	FLU-37T-20	-2	
	208Y/120	208Y/120	5	Tall	FLU-37T-20	-1	-I
	220Y/127	220Y/127	5	Short	FLU-37S-22	-1	
	220Y/127	220Y/127	17	Tall	FLU-37T-22	-2	

Battery Option

- 1 = 1 string
- 2 = 2 string
- 0 = Without Batteries

Other Options	Suffix	Notes
Isolation Transformer	-I	Isolation transformer required for use with delta (3-wire) input. Standard is K20 rated.

220V Models are not listed to UL, CUL, or CSA.

Accessories

There are several external accessories that are designed to work with the FirstLine UPS:

- The FirstLine Extended Run Time Battery Cabinet allows the addition of up to three additional battery strings per cabinet to increase the available battery run time. Up to three FirstLine Extended Run Time Battery Cabinets can be used with each UPS. The cabinet is styled to match the FirstLine UPS. The battery cabinet can be ordered with an optional disconnect switch or a user provided disconnect arrangement can be used. The FirstLine Extended Run Time Battery Cabinet is listed to UL1778.
- The FirstLine Options Cabinet is a steel enclosure designed to hold option devices to be used in conjunction with the FirstLine UPS. The enclosure is styled to match the UPS and includes provisions for terminating a number of conduits to facilitate wiring. Available option devices include several transformers, a Maintenance Bypass Switch (MBS), output panelboards, and output meters. The FirstLine Options Cabinet is listed to UL1778.
- The FirstLine Wall-Mounted Maintenance Bypass Switch is the same MBS switch arrangement that is available in the Options Cabinet, but in a more compact enclosure that mounts on a wall. The FirstLine Wall-Mounted Maintenance Bypass Switch is listed to UL1778.
- The FirstLine UPS is also available together with the FirstLine Extended Run Time Battery Cabinet to form the FirstLine UPS Emergency Lighting System which is listed to UL924.
- Contact Staco Energy Company, your tailored power solutions provider, for additional information.

SECTION 2

Safety Warnings







**IMPORTANT SAFETY INSTRUCTIONS
SAVE THESE INSTRUCTIONS**

This manual contains important instructions that you should follow during installation and maintenance of the UPS and batteries. Please read all instructions before operating the equipment and save this manual for future reference.

READ AND FOLLOW ALL SAFETY INSTRUCTIONS

- a. Do not use outdoors.
- b. Do not route wiring across or near hot surfaces.
- c. Do not install near gas or electric heaters.
- d. Use caution when servicing batteries. Battery acid can cause burns to skin and eyes. If acid is spilled on skin or in eyes, flush acid with fresh water and contact a physician immediately.
- e. Equipment should be installed where it will not readily be subjected to tampering by unauthorized personnel.
- f. The use of accessory equipment not recommended by the manufacturer may cause an unsafe condition.
- g. Do not use this equipment for other than intended use.

Table 2-Symbols

	Danger / Risk of Electric Shock
	Caution
	Risk of Explosion
	Note
	Ground Connection
	Electrostatic Sensitive Device

DANGER

This UPS contains LETHAL VOLTAGES. All repairs and service should be performed by AUTHORIZED SERVICE PERSONNEL ONLY. There are NO USER SERVICEABLE PARTS inside the UPS.

WARNING

- This UPS contains its own energy source (batteries). The UPS output may carry live voltage even when the UPS is not connected to an AC supply.
- To reduce the risk of fire or electric shock, install this UPS in a temperature and humidity controlled, indoor environment, free of conductive contaminants. Do not operate near water or excessive humidity (95% maximum).
- Input and output over-current protection and disconnect switches must be provided by others.

CAUTION

Batteries can present a risk of electrical shock or burn from high short circuit current. Observe proper precautions. Servicing should be performed by qualified service personnel knowledgeable of batteries and required precautions. Keep unauthorized personnel away from batteries.



Risk of explosion if batteries are replaced by an incorrect type. Replace with same type and rating only.

Proper disposal of batteries is required. Refer to your local codes for disposal requirements.

Never dispose of batteries in a fire. Batteries may explode when exposed to flame.

SECTION 3

UPS Setup

This section describes:

- Equipment inspection
- Floor loading and clearances
- Removing and replacing the cabinet panels
- Unloading the cabinet(s)

Inspecting The Equipment

If any equipment has been damaged during shipment, keep the shipping and packing materials for the carrier or place of purchase and file a claim for shipping damage. If you discover damage after acceptance, file a claim for concealed damage.

To file a claim for shipping damage or concealed damage: 1) File with the carrier within 15 days of receipt of the equipment, 2) Send a copy of the damage claim within 15 days to your service representative.

Floor Loading

When planning the installation, consider the UPS weight for floor loading. The strength of the installation surface must be adequate for point and distributed loading. The approximate weights are shown in the following table.

Table 3-Model Floor Loadings

STANDARD MODEL FLOOR LOADING		
25-30-37.5 KVA	Maximum Weight	Point Loading
Standard	1253 Lbs (568 kg)	399 lb/in ² (28 kg/cm ²)
Extended Run	1765 Lbs (801 kg)	562 lb/in ² (39 kg/cm ²)
480 I/O	1855 Lbs (841 kg)	590 lb/in ² (42 kg/cm ²)

Clearances

The following clearances are recommended for the FirstLine UPS.

From Front of Cabinet	36" (91.4 cm) working space
From Back of Cabinet	12" (30.5 cm)
From Side of Cabinet	Minimum 24" (61 cm)

Unloading the Cabinet(s)

The following tools are required for unloading the cabinet(s):

- Wrenches for 1/4" bolts and 1/2" nut
- Forklift

CAUTION



The UPS and optional cabinets are heavy (see Table 3). Unloading the cabinets requires at least two people to safely remove the cabinets from the pallet.

To remove the UPS or optional cabinets from the ship pallet:

1. Remove all banding, wrapping, and foam protectors.
2. Loosen the six 1/2" nuts and washers securing the shipping brackets to the pallet (see Figures 2 and 3).
3. Remove and discard the four 1/4" bolts and washers securing the shipping brackets to the cabinet side panels. Also remove the four 1/4" bolts and washers the bracket surrounds but does not touch. Save these as they must be reinstalled later. Pull the brackets away from the cabinet.

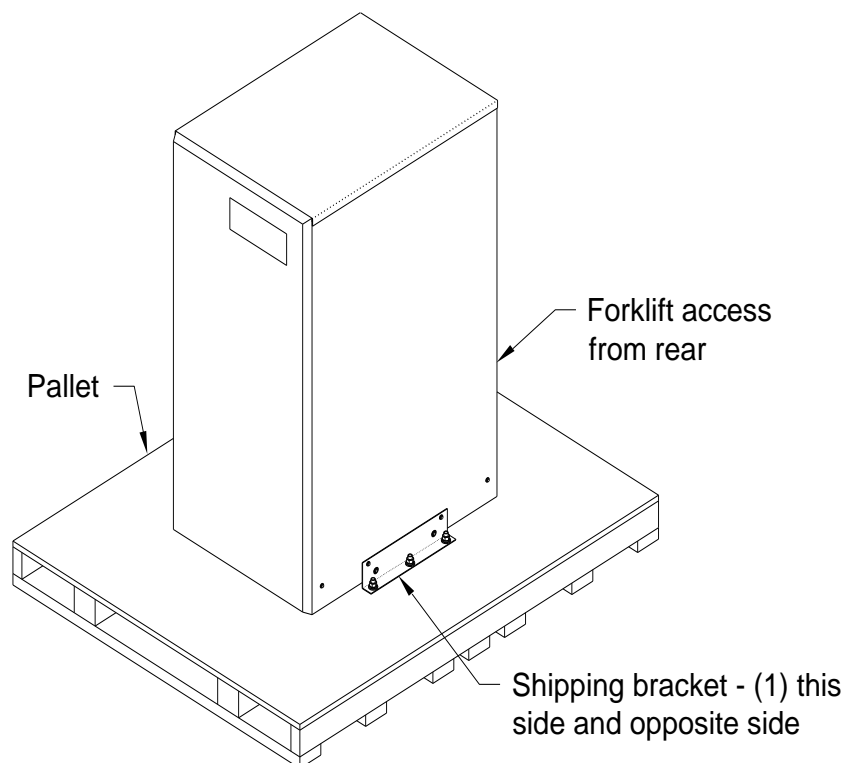

Figure 2-UPS on pallet

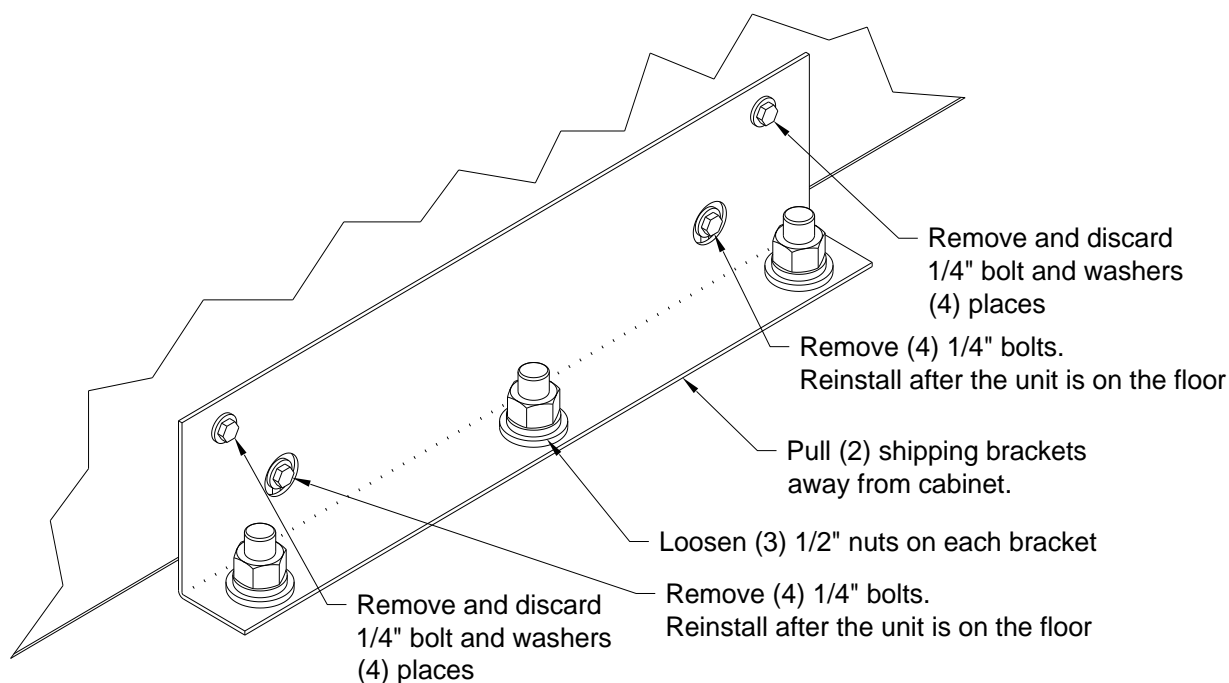

Figure 3-Shipping Bracket

4. Remove the front cover (see Figure 9) before inserting the lifting forks.
5. Ensure that the four (4) leveling feet are raised so that they will not touch the floor when the cabinet is placed on the floor.
6. Lift the cabinet with a forklift from the rear of the unit, one to two inches (1"-2" [2.5-5cm]) above the pallet (see figure 5).
7. Slide the pallet completely away from the raised cabinet.
8. Slowly lower the cabinet to the floor or other appropriate flat service.
9. Reinstall the front cover and add (4) 1/4" bolts and washers (see figure 3).
10. Roll the cabinet to the desired location
11. Do not move the cabinet to another location by forklift , as the cabinets are heavy and may fall.



DO NOT ALLOW THE FORKLIFT TO MOVE WHILE THE CABINET IS RAISED, ONLY MOVE THE CABINET VERTICALLY TO REMOVE THE PALLET FROM UNDER THE CABINET.

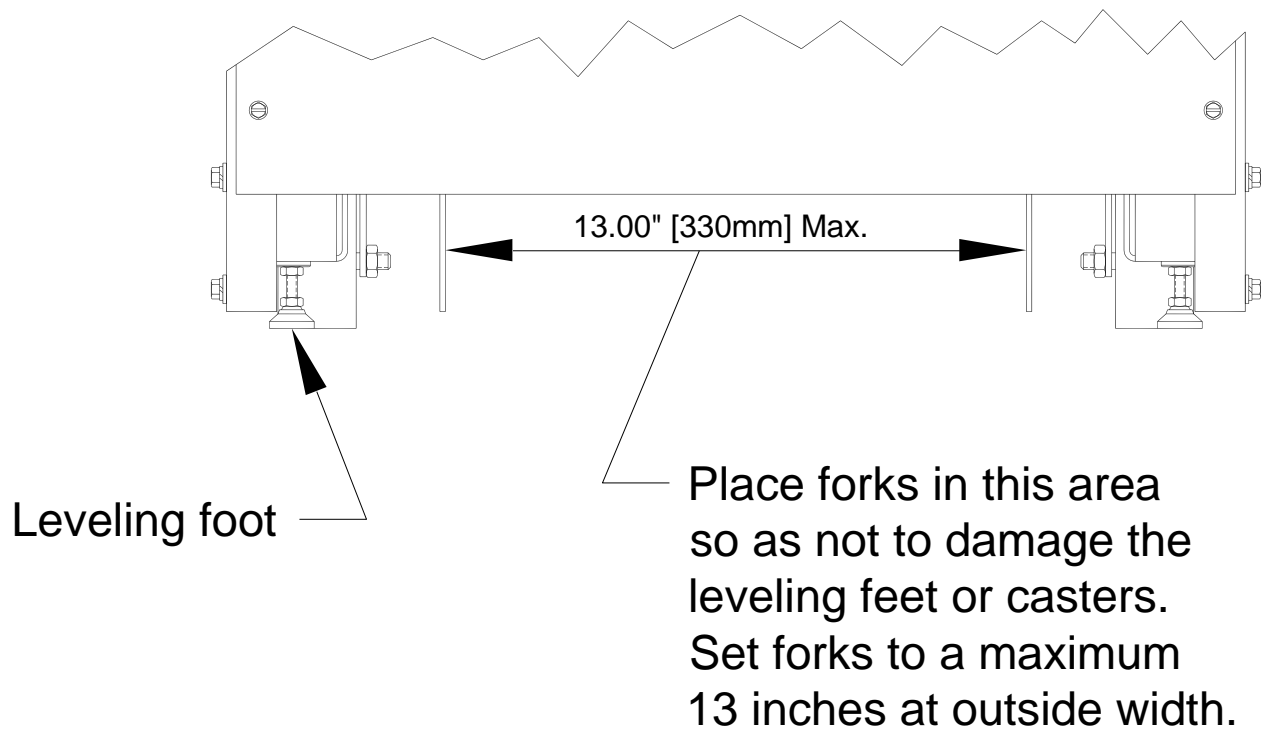

Figure 4-Lifting fork area

Placing The Cabinet

Once the cabinet has been rolled into position, remove the front panel to access the front leveling feet by pulling the panel outward at the bottom of the unit until it unsnaps and then lift up and off the cabinet (see figure 9). Adjust the leveling feet as shown in figure 5.

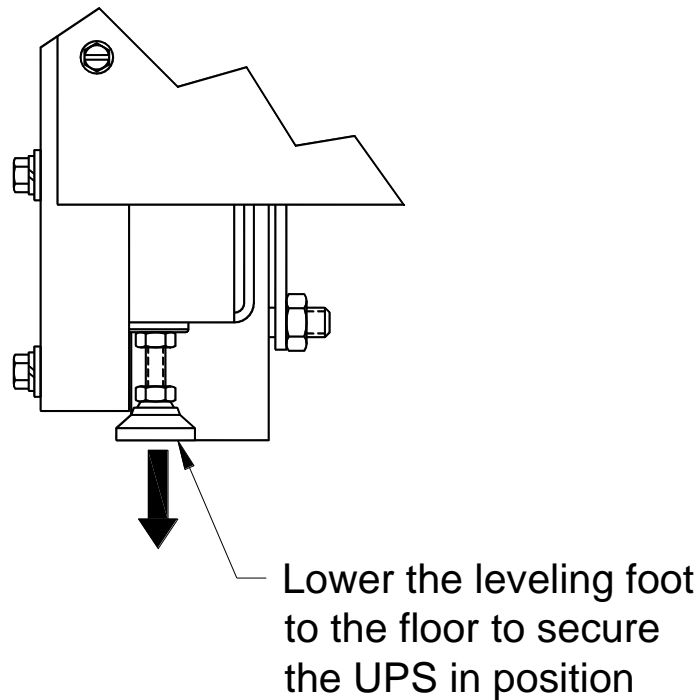

Figure 5-Leveling foot being adjusted down to the floor

SECTION 4

Electrical Installation

The FirstLine has the following power connections:

- 3-phase (L1, L2, and L3), neutral, and ground connection for rectifier/bypass input
- 3-phase (L1, L2, and L3), neutral, and ground connection for load output

The input neutral connection is not used when the UPS is equipped with the optional isolation transformer.

The nominal input/output voltages are:

- 120/208 VAC is available in the short cabinet or tall cabinet.
- 208 VAC, 60 Hz delta input is available when using the tall cabinet with an input isolation transformer.
- 127/220 VAC is available in the short or tall cabinet.
- 480V, 60 Hz input is available when using the tall cabinet with an input transformer, (isolation or auto.)
- 480/480 Vac is available when using the tall cabinet with an input and output transformer.

Input and output over current protection and disconnect switch must be provided by others.

WARNING



Only qualified service personnel (such as a licensed electrician) should perform the UPS installation and initial startup. Risk of electrical shock.

Wiring Preparation

To begin wiring the UPS:

1. Verify that the electrical connections to the installation site have been properly installed.
2. A wall-mounted, user-supplied, readily-accessible disconnection device must be incorporated in the input wiring.

Compare the circuit breaker ratings to the ones in Table 6 on page 14.

3. Switch off utility power to the distribution point where the UPS will be connected. Be absolutely sure there is no power.
4. Determine your equipment's grounding requirements according to your local electrical code.
5. Remove the UPS rear panel.
6. Conduit landing plates are located at the rear bottom of the base to accommodate bottom wire entry to the cabinet (see figure 6).

Remove plate and drill or punch hole to fit conduit bushing with Greenlee punch or similar device. Make certain that the bushing will be clear in the opening in the base. Mount bushing to plate and tighten to manufacturer's recommendations. Replace the plate and mount conduit.

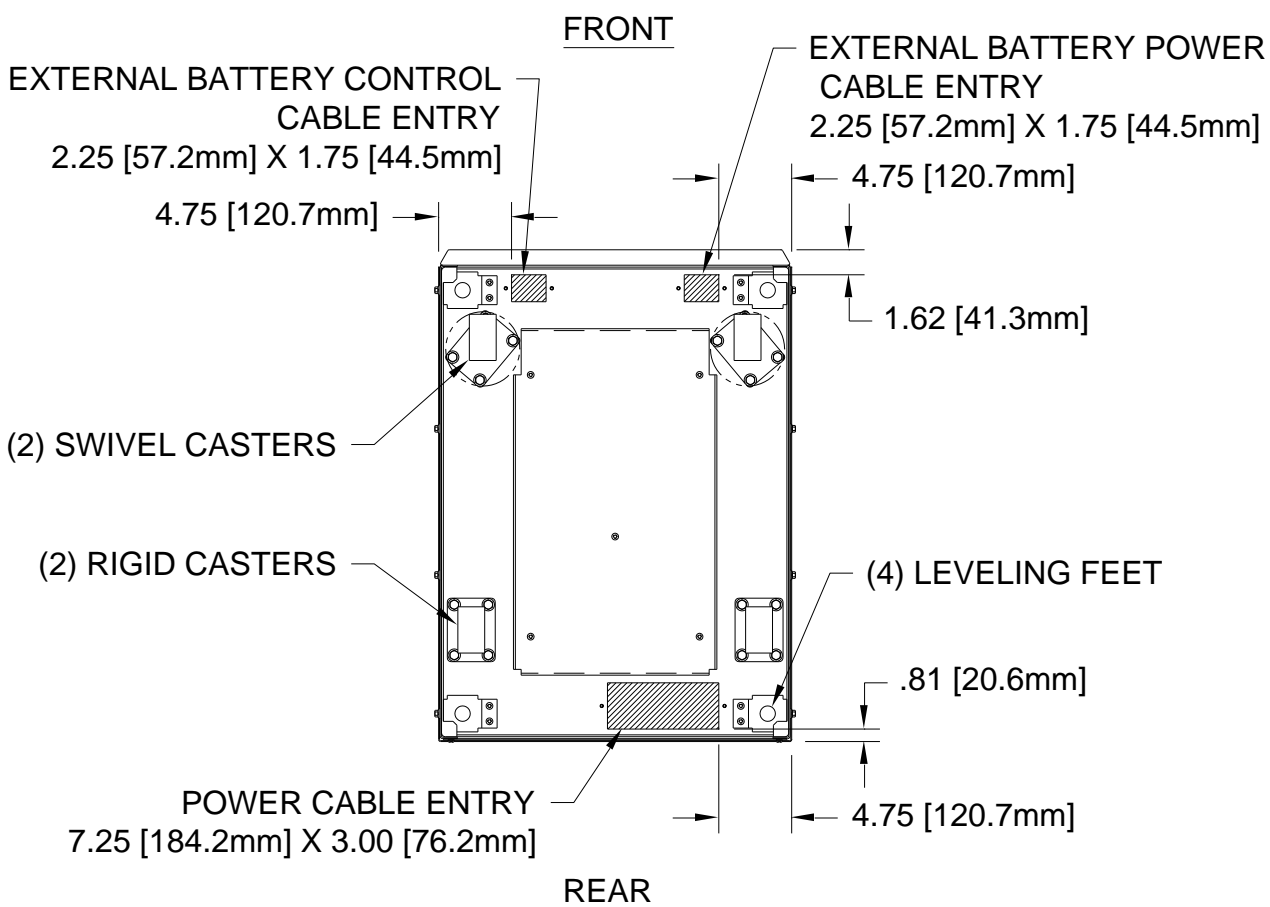

Figure 6-Bottom View

Wiring Installation

1. Unscrew and remove the rear panel.
2. Connect the input wires to the proper terminals shown in Figure 7. Insure proper phase rotation. Input neutral is not required if the UPS is equipped with an optional input isolation transformer.
3. Connect the output wires to the proper terminals shown in Figure 7.
4. Replace the rear panel.

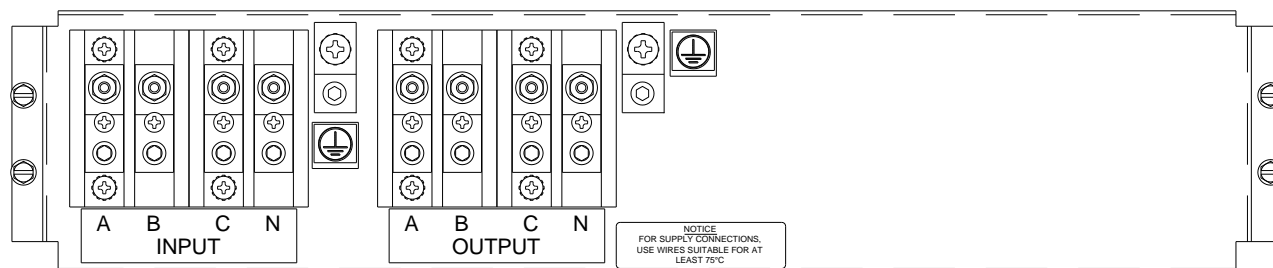

Figure 7-Terminal Blocks

Table 4-Input/Output Terminal

INPUT/OUTPUT TERMINAL TIGHTENING TORQUE	
#2/0 - #6 AWG	120 inch-pounds
#8 - #12 AWG	50 inch-pounds

Table 5-Ground Lugs

GROUND LUGS TIGHTENING TORQUE	
#10 AWG	35 inch-pounds
#8 AWG	40 inch-pounds
#4 - #6 AWG	45 inch-pounds
#1/0 - #2 AWG	50 inch-pounds

Table 6-FirstLine UPS 25-37.5 kVA Current Requirements

UPS Rating	Input Voltage	Input Transformer Option	Max. Input Current (A) Allowed for Specified Branch Protector	Maximum Allowable Branch Circuit Protection (A)
25 kVA	208 V	None	80	100
25 kVA	208 V	Isolation	80	100
25 kVA	220 V	None	80	100
25 kVA	480 V	Standard auto	40	50
25 kVA	480 V	Isolation	40	50
30 kVA	208 V	None	100	125
30 kVA	208 V	Isolation	100	125
30 kVA	220 V	None	100	125
30 kVA	480 V	Standard auto	48	60
30 kVA	480 V	Isolation	48	60
37 kVA	208 V	None	120	150
37 kVA	208 V	Isolation	120	150
37 kVA	220 V	None	120	150
37 kVA	480 V	Standard auto	60	75
37 kVA	480 V	Isolation	60	75

UPS Rating	Output Voltage	Rated Max. Output Current (A) (note 2)		Maximum Allowable Circuit Protection (A)
		PF=.8	PF=1	
25 kVA	208 V	70	55	(note 1)
25 kVA	220 V	66	52	(note 1)
25 kVA	480 V	30	24	50
30 kVA	208 V	83	66	(note 1)
30 kVA	220 V	78	63	(note 1)
30 kVA	480 V	36	29	60
37 kVA	208 V	104	83	(note 1)
37 kVA	220 V	98	78	(note 1)
37 kVA	480 V	45	36	75

Note 1: Output circuit protection requirement determined by distribution circuit.

Note 2: Do not apply continuous loads in excess of rated maximum output current. If the power factor of the load is not known, use PF=1. The UPS controls will permit transient loads within the limits described in the OVERLOAD section of this manual.

Wiring Specifications and Diagrams

Note: Input neutral must be wired for proper operation or the UPS will not start.



Note: *Do not* over-tighten the screws; be sure to use the specified tightening torque values shown in Table 4, Table 5, and Table 6.

25 KVA, 208V: **CAUTION** to reduce the risk of fire, connect only to a circuit provided with 100 amperes maximum branch circuit protection in accordance with the National Electrical Code, ANSI/NFPA 70.

25 KVA, 480V: **CAUTION** to reduce the risk of fire, connect only to a circuit provided with 50 amperes maximum branch circuit protection in accordance with the National Electrical Code, ANSI/NFPA 70.

30 KVA, 208V: **CAUTION** to reduce the risk of fire, connect only to a circuit provided with 125 amperes maximum branch circuit protection in accordance with the National Electrical Code, ANSI/NFPA 70.

30 KVA, 480V: **CAUTION** to reduce the risk of fire, connect only to a circuit provided with 60 amperes maximum branch circuit protection in accordance with the National Electrical Code, ANSI/NFPA 70.

37.5 KVA, 208V: **CAUTION** to reduce the risk of fire, connect only to a circuit provided with 150 amperes maximum branch circuit protection in accordance with the National Electrical Code, ANSI/NFPA 70.

37.5 KVA, 480V: **CAUTION** to reduce the risk of fire, connect only to a circuit provided with 75 amperes maximum branch circuit protection in accordance with the National Electrical Code, ANSI/NFPA 70.

220V units should be equipped with the same maximum rated breaker as 208V units.

Table 7-Terminal Block Wiring

UPS Rating	Voltage	Input Transformer Type	Phase Conductor Min/Max	Neutral Conductor Min/Max	Neutral Conductor with non-linear loads Min/Max	Ground Wire Min/Max
25kva	208/120	NA	#2/2-0	#2/2-0	#2/2-0	#8/1-0
	208	isolation	#2/2-0	(none)	(none)	#8/1-0
	220/127	NA	#2/2-0	#2/2-0	#2/2-0	#8/1-0
	480/277	auto	#4/2-0	#4/2-0	#4/2-0	#10/1-0
	480	isolation	#4/2-0	(none)	(none)	#10/1-0
30kva	208/120	NA	#1-0/2-0	#1-0/2-0	#1-0/2-0	#6/1-0
	208	isolation	#1-0/2-0	(none)	(none)	#6/1-0
	220/127	NA	#1-0/2-0	#1-0/2-0	#1-0/2-0	#6/1-0
	480/277	auto	#4/2-0	#4/2-0	#4/2-0	#10/1-0
	480	isolation	#4/2-0	(none)	(none)	#10/1-0
37.5kva	208/120	NA	#1-0/2-0	#1-0/2-0	#1-0/2-0	#6/1-0
	208	isolation	#1-0/2-0	(none)	(none)	#6/1-0
	220/127	NA	#1-0/2-0	#1-0/2-0	#1-0/2-0	#6/1-0
	480/277	auto	#3/2-0	#3/2-0	#3/2-0	#8/1-0
	480	isolation	#3/2-0	(none)	(none)	#8/1-0
OUTPUT -Minimum wire size required to support rated load. Smaller wire may be used if rated load current is not needed and the appropriate circuit protection is applied.						
UPS Rating	Voltage	Output Transformer Type	Phase Conductor	Neutral Conductor	Neutral Conductor with non-linear loads	Ground Wire
25 kVA	208/120	NA	#2	#2	#2	#8/1-0
	220/127	NA	#2	#2	#2	#8/1-0
	480/277	auto	#4	#4	#4	#10/1-0
30 kVA	208/120	NA	#1	#1	#1	#6/1-0
	220/127	NA	#1	#1	#1	#6/1-0
	480/277	auto	#4	#4	#4	#10/1-0
37.5kVA	208/120	NA	#1-0	#1-0	#1-0	#6/1-0
	220/127	NA	#1-0	#1-0	#1-0	#6/1-0
	480/277	auto	#4	#4	#4	#8/1-0

Note: No output circuit protection is required if the output conductor sizes are at least as large as the input conductors, unless the UPS is equipped with an input isolation transformer. If the UPS is equipped with an input isolation transformer, the UPS is considered a separately derived source and circuit protection for the output conductors must be provided.

Use at least 75°C-rated copper wire. Minimum wire size is based on 120/208 full load ratings applied to NEC Code Table 310-16. Code may require a large AWG size than shown in this table because of temperature, number of conductors in the conduit, or long service runs. Follow local requirements.

Per NEC article 300-20(2), all three-phase conductors must be run in the same conduit. Neutral and ground must be run in the same conduit as the phase conductors.

Conduit to be sized to accommodate one neutral conductor the same size as the phase conductor and one ground conductor. If two neutral conductors or an oversized neutral conductor are to be installed, check the size of the conduit needed to accommodate the extra wire or size and use that conduit size in place of the conduit size listed. Conduit sizes can be chosen from NEC Table C1, type letters RHH, RHW, RHW-2, TW, THW, THHW, THW-2.

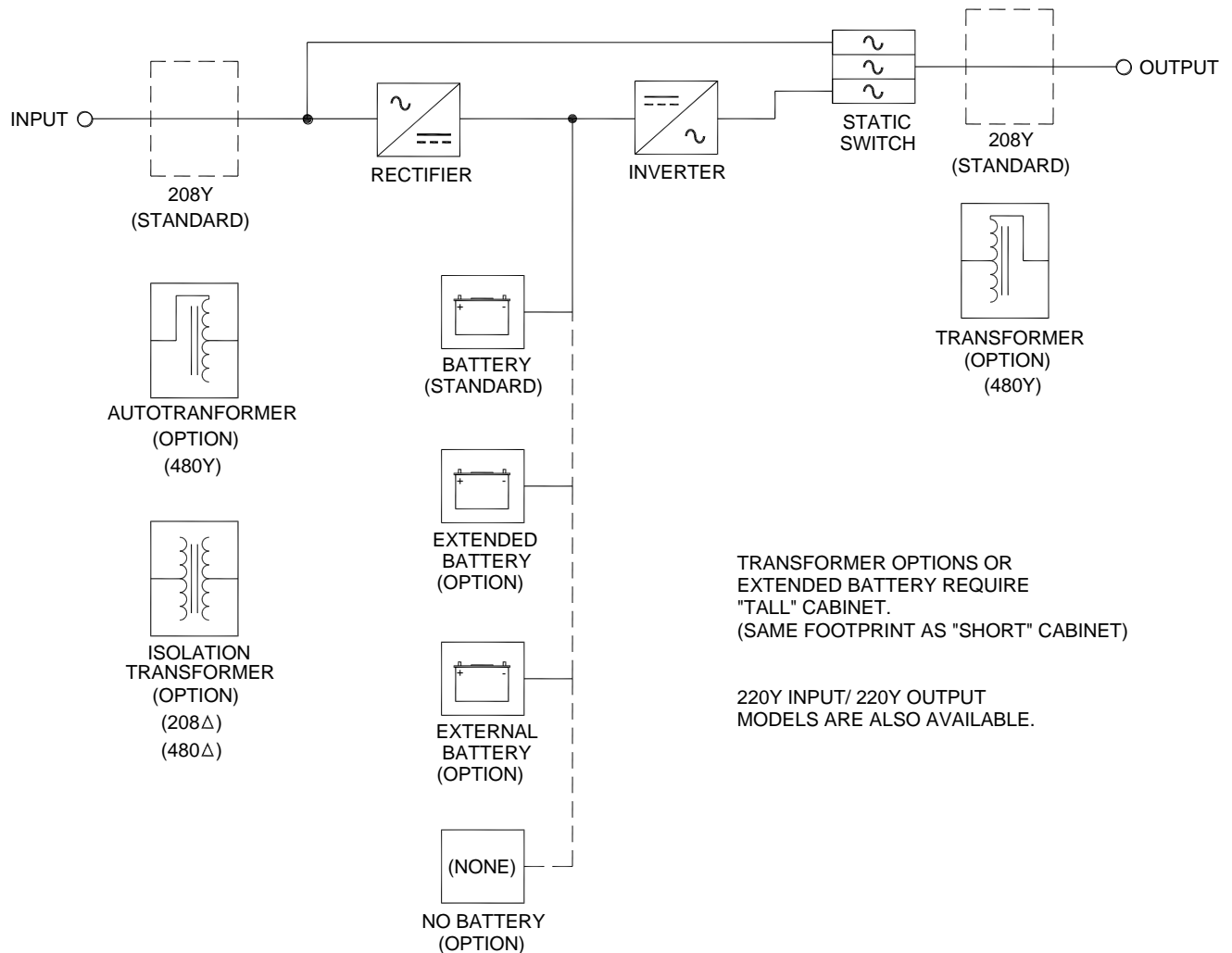

Figure 8-UPS Wiring-Single Line Diagram

Removing and Replacing The Front Panel

1. Pull the top of the panel outward until the ball studs unsnap.
2. Lift the panel up and off the cabinet.

To replace the panel:

1. Lower the shoulder screws at the top of the panel into the keyhole slots on the cabinet.
2. Press the panel inward until the ball studs snap into place.

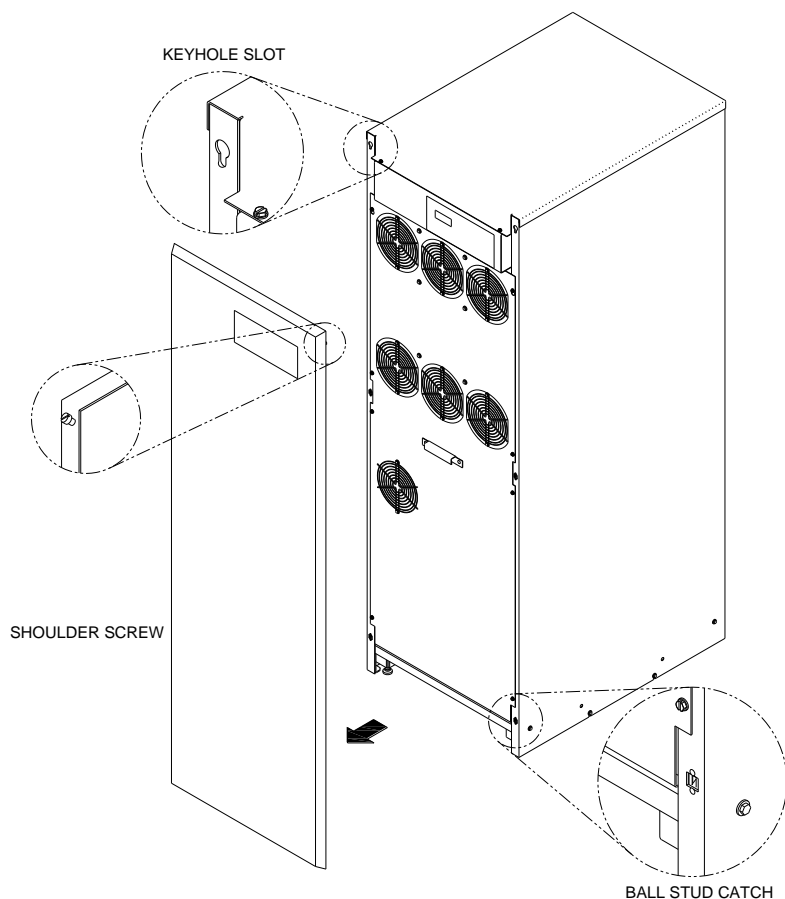

Figure 9-Removing the UPS Front Panel

Connect The Internal Battery

To be performed by authorized service personnel:

1. Remove front cover panel and interior panel.
2. Remove and discard shipping support panel mounted in front of the battery trays.
3. Inspect battery trays for signs of damage. Verify that all terminal connections are sound.
4. Use a voltmeter to verify that the battery string is above 420 VDC at the battery plug shown in figure 10.
5. Verify that the blue plug of the lower tray is connected to the blue plug of the upper tray.



Never connect the two plugs from the same tray together. Severe damage and injury could result.

6. If an Extended Battery Cabinet is to be connected, do so at this time. Refer to the User's manual for the FirstLine Extended Run Time Battery Cabinet. Also, refer to the special notes in Section 8 of this manual.
7. Reference figure 10. Connect the battery plug to the DC input plug.
8. If the UPS is equipped with a second battery string, repeat steps 4, 5, and 7 for the second battery string.
9. Replace front panels.

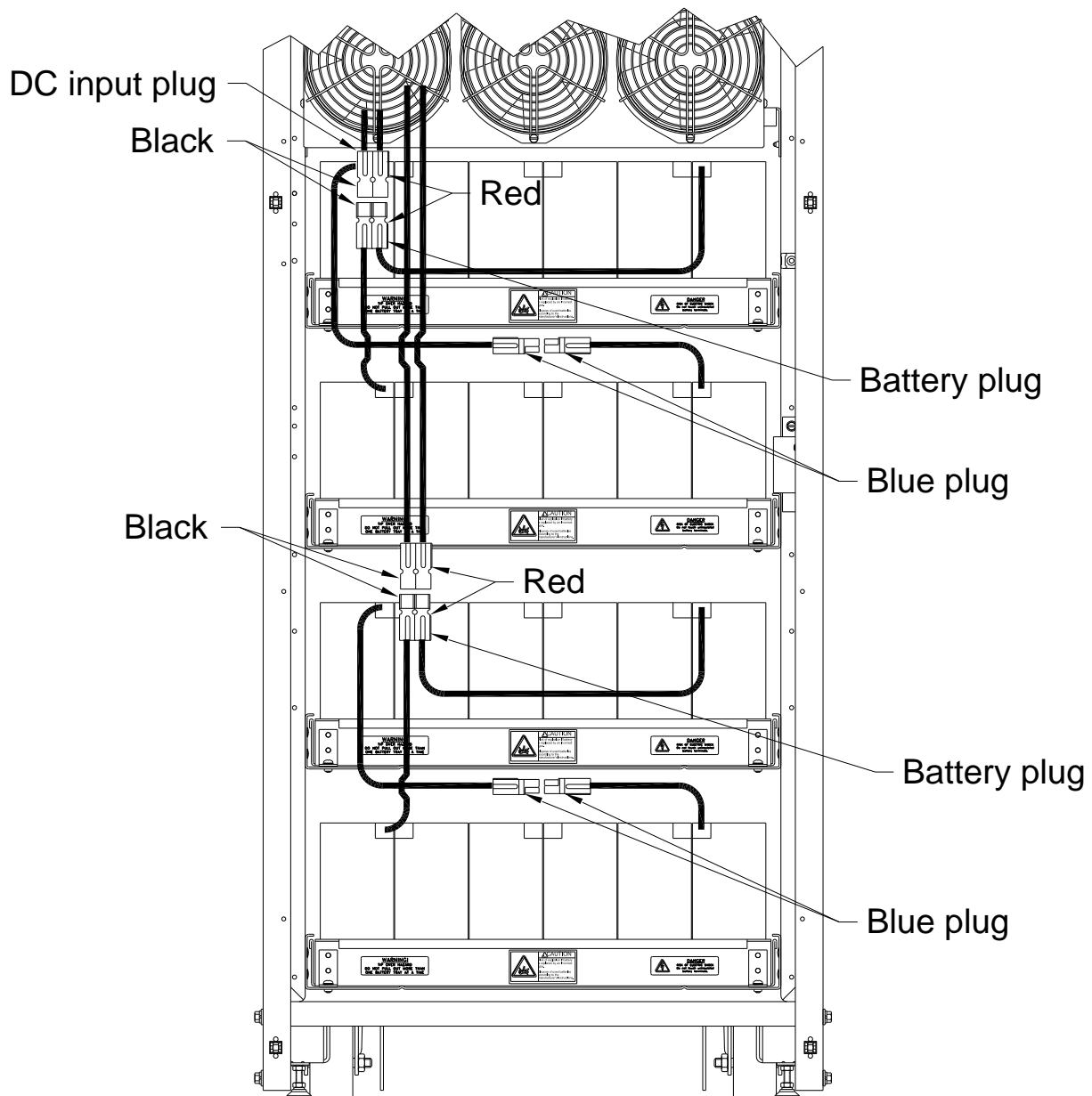

Figure 10-Internal Battery

SECTION 5

Communication

Figure 11 shows the location of the communication options and terminals on the UPS.

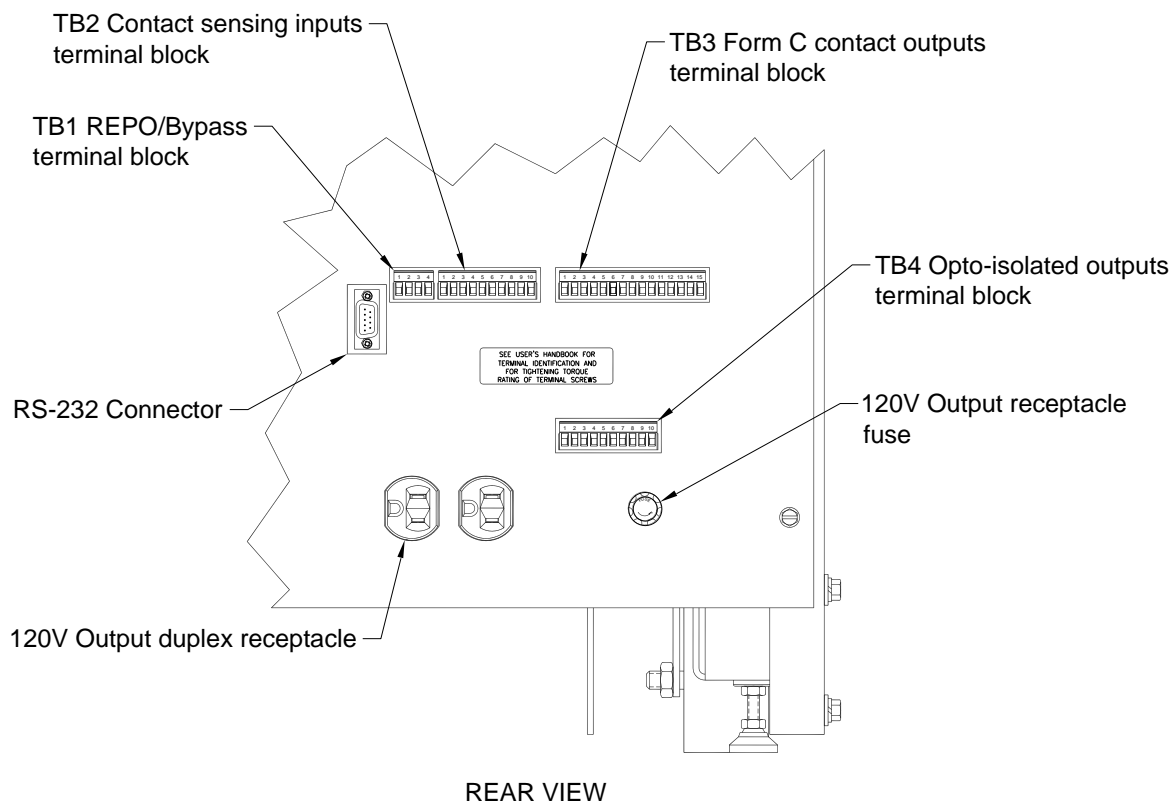

Figure 11-Communication Options and Control Terminals

CAUTION: The 120V receptacle on the rear panel must only be used to power Staco supplied communications accessories.



Note: TB1, TB2, TB3, TB4 plug-in terminal blocks, fuse, and fuse cap are shipped in the zip-lock bag with this manual. Install them before powering on the UPS.

Customer Interface

The Customer Interface is located on the rear cover of the UPS. There are seven dry contact inputs that function as follows:

- TB1 terminals 1 and 2-Remote Emergency Power Off (REPO) contact closure causes immediate shutdown of the UPS. Contact the factory if a normally closed REPO switch is required.
- TB1 terminals 3 and 4-Bypass Switch Sensing (To Staco MBS, if present).
- TB2 terminals 1 and 2-Battery Charge Inhibit. For future use.
- TB2 terminals 3 and 4-Reduced Current Operation. For future use.
- TB2 terminals 5 and 6-Automatic Restart Inhibit. For future use.
- TB2 terminals 7 and 8-not defined.
- TB2 terminal 9 and 10-not defined

➤ There are five sets of form-C dry contact available as outputs. They are capable of switching up to 30 volts (AC or DC) at up to 1 amp. Listed in order of NO, COM, NC.

- TB3 terminals 1, 2, 3 – running on inverter.
- TB3 terminals 4, 5, 6- battery discharging.
- TB3 terminals 7, 8, 9- low battery reserve.
- TB3 terminals 10, 11, 12- on bypass.
- TB3 terminals 13, 14, 15- alarm present.

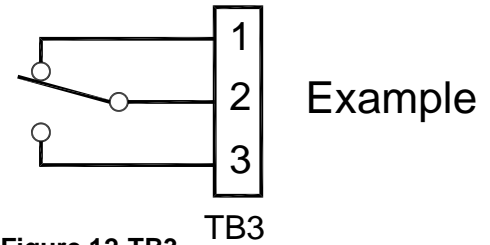

Figure 12-TB3

There are five sets of optically isolated open collector outputs available. They are capable of switching up to 30 volts DC and up to 3 milliamps. Listed in order of Emitter, Collector.

- TB4 terminals 1,2 – running on inverter
- TB4 terminals 3,4 – battery discharging
- TB4 terminals 5,6 – low battery reserve
- TB4 terminals 7,8 – on bypass
- TB4 terminals 9, 10 – alarm present

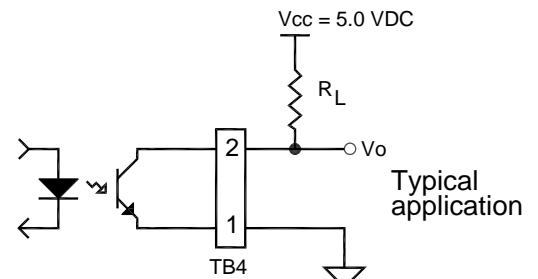

Figure 13-TB4

An RS-232 DCE three wire interface is available. The UPS shipped with an installation CD containing monitor software and an RS-232 cable. The monitor software will allow a single user to connect the UPS to a computer via the RS-232 port for local monitoring of UPS operation.

For advanced monitoring Ethernet and SNMP are supported via the RS-232 interface with an external adaptor. A 120 volt AC outlet has been provided on the back panel of the UPS for powering the external adaptor. Consult the factory for more details.

The local RS-232 monitor function cannot be used at the same time as the external monitoring adaptor.

If the UPS is connected to the Staco Maintenance Bypass Switch, there are required connections between TB1-3, TB1-4, TB3-10, TB3-11 and the MBS. If an MBS is present, TB3-10, 11, 12 (“On Bypass”) contacts are not available to the user.

Table 8-Torque Values for TB1, 2, 3, 4

TORQUE VALUES FOR TERMINAL BLOCKS ON CUSTOMER INTERFACE BOARD	
#22 - #12 AWG	4.4 inch-pounds

SECTION 6

Operation

This SECTION contains information on how to use the FirstLine UPS, including front panel operation, UPS startup and shutdown.

Control Panel Functions

The UPS has LCD with backlight. It provides useful information about the UPS itself, load status, events, measurements, and setting (see figure 14).

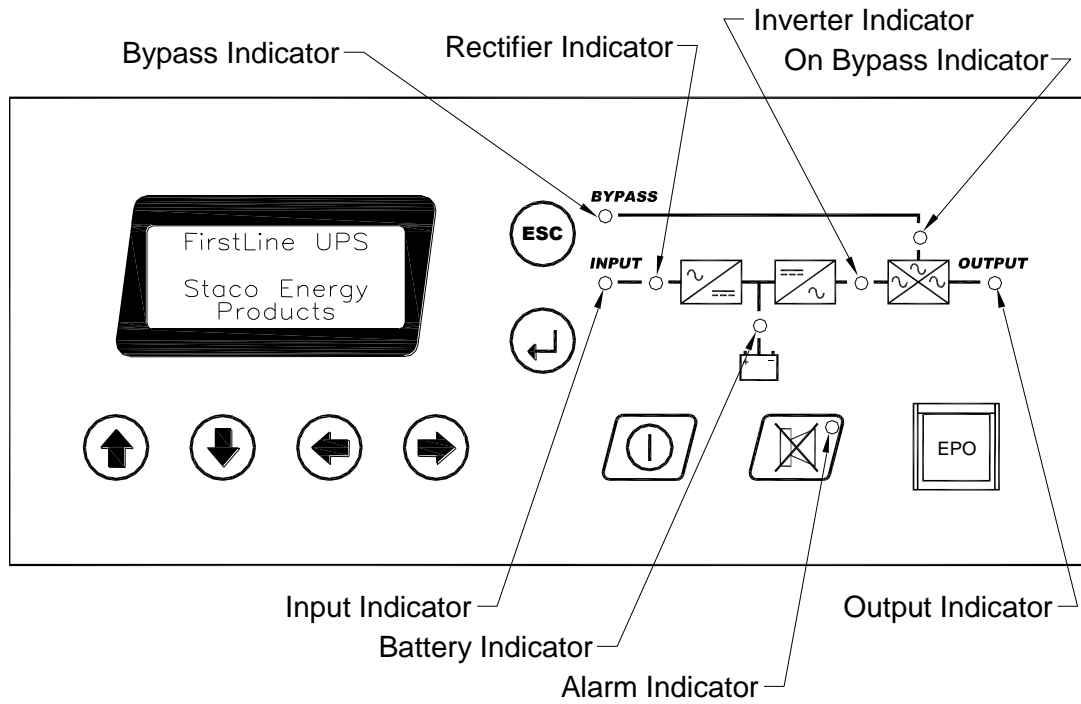

Figure 14-FirstLine Front Panel Display and Control Module

The following table shows the indicator status and description:

Indicator	Status	Description
Bypass	Off	Bypass input voltage or frequency not qualified
Bypass	Green	Bypass input voltage or frequency qualified
Bypass	Yellow	Inverter output not synchronized to bypass input
Bypass	Red	Bypass input voltage has incorrect phase sequence
Input	Off	Rectifier input voltage or frequency not qualified
Input	Green	Rectifier input voltage and frequency qualified
Input	Red	Rectifier input voltage has incorrect phase sequence
Rectifier	Off	System OFF or Rectifier input not qualified
Rectifier	Green	Rectifier is running normally
Rectifier	Yellow	Rectifier is running at input power limit
Rectifier	Red	Rectifier failure or DC Bus Fault, call for Service
Battery	Off	System OFF
Battery	Green	Battery is being charged or is at full charge
Battery	Yellow	Battery is discharging
Battery	Red	Battery fault or no battery present
Inverter	Off	System OFF or on Bypass
Inverter	Green	Running ON INVERTER (normal mode)
Inverter	Yellow	Bus voltage out of range or tripped on overcurrent
Inverter	Red	Inverter failure, call for service
On Bypass	Off	System OFF or not on Bypass (normal mode)
On Bypass	Green	ON Bypass
On Bypass	Yellow	On Bypass, overload present, reduce load before system shuts down
On Bypass	Red	Static Switch Failure, Do Not Operate UPS, call for Service
Output	Off	System off
Output	Green	Output is present (On Inverter or on Bypass)
Output	Yellow	Output is overloaded, reduce load before system shuts down
Output	Red	Output failed or EPO was activated or REPO was activated
Alarm	Off	No alarms are present
Alarm	Yellow	An alarm is present

Table 9-Indicator Status and Description

Display Functions

As the default or after 15 minutes of inactivity, the LCD displays the selectable startup screen. The default is the Staco Energy Products Co. logo and can be changed to the Mimic screen in the User Settings menu.

The backlit LCD automatically dims after a long period of inactivity. Press any button to restore the screen.

Use the two middle buttons (↑ and ↓) to scroll through the menu structure. Press the → button to enter a submenu. Press the ← button to select an option. Press the **ESC** button to cancel or return to the previous menu.

The following table shows the basic menu structure.

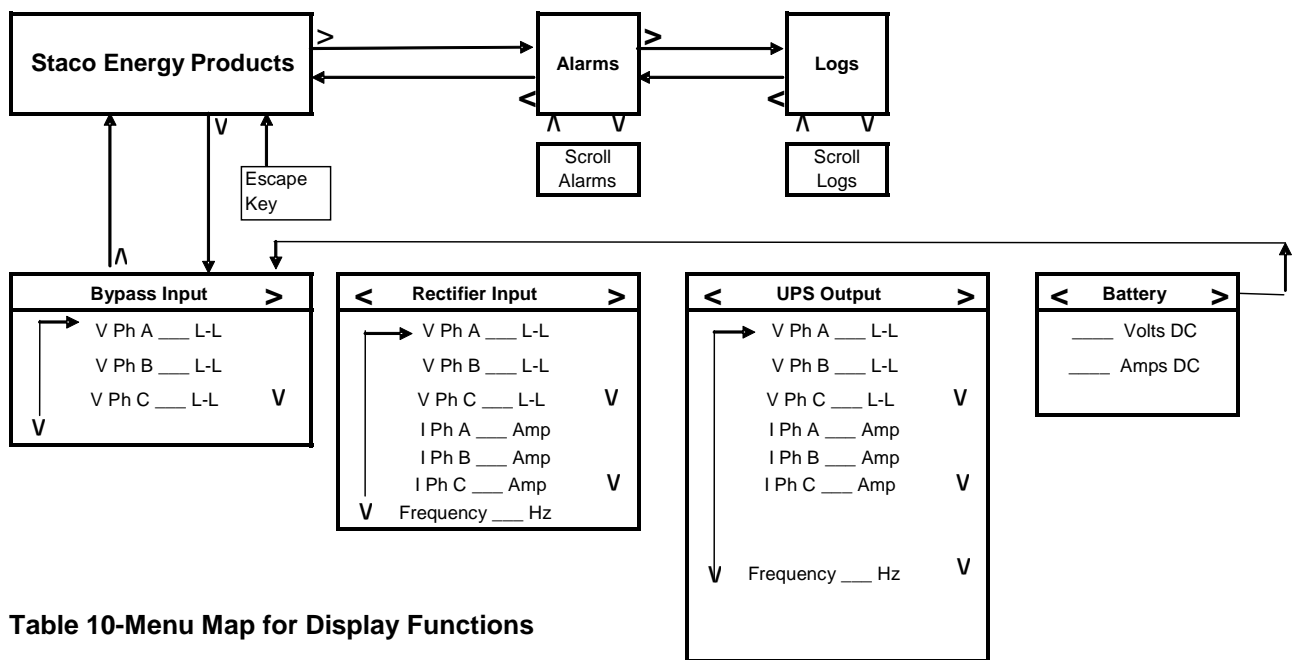



Table 10-Menu Map for Display Functions

SECTION 7

Initial Start Up

To be performed by authorized service personnel.

1. Inspect for damage. Remove front cover panel, inner front access panel, front shipping support panel, top cover, and rear panel. Look for signs of damage due to handling including bent supports, loose components, etc.
2. Connect input power source and load to terminal blocks at rear of unit as described in Section 4. Before apply power to Ups, verify that the correct voltage is available and that the phase sequence is correct (A-B-C).
3. If an external bypass switch is to be used, contact the factory for the correct method to interface contact sensing to the UPS.
4. Double check that there is no visible damage to the battery. Insure the battery is connected as described in Section 4.
5. Reinstall the rear cover, the top cover, and the front inner access panel. Reinstall the decorative front panel.
6. If one or more Extended Battery Cabinets are connected to the UPS, close the circuit breaker on each cabinet, if they are equipped with this option.
7. Apply power to the UPS.
8. Press the on/off button  to start the UPS.

Normal Operation

To start the UPS, press the on/off power button . If the bypass input is qualified (voltage, frequency, and phase sequence correct), the UPS will start on bypass. The rectifier and inverter will automatically start and the static switch will transfer the load to the inverter.

To stop the UPS, press the on/off button.

In an emergency, the UPS can be stopped by lifting the guard and pressing the “EPO” button (Emergency Power Off). Activation of Emergency Power Off, either via the front panel EPO button or via the Remote Emergency Power Off function (TB1 on the Customer Interface), will also cause the system to reset, interrupting any display or communication process that is underway.

The output circuits of the UPS; should not be considered safe unless the UPS is Off AND the input power source to the UPS has been removed by opening the input disconnect device which is external to the UPS.

If one or more Extended Battery Cabinets are connected to the UPS, do not open the (optional) circuit breaker on any cabinet. If the circuit breaker is open, do not close the circuit breaker while the UPS is operating. See Section 8 for the proper procedure to close the circuit breaker.

Manual Transfer to Bypass

Verify that the bypass input is qualified by observing that the bypass indicator is green. While holding down the ESC key, press the up-arrow key. When the conditions are met for a transfer to bypass (bypass input is qualified and inverter is synchronized to bypass), the static switch will transfer the load to bypass. After a few seconds, the mimic display will update to show this.

Manual Transfer to Inverter

This procedure enables an automatic transfer to inverter. While holding down the ESC key, press the down-arrow key. When the conditions are met for a transfer to inverter (inverter is running and synchronized to bypass), the static switch will transfer the load to inverter. After a few seconds, the mimic display will update to show this.

External Bypass Arrangement

If the UPS is connected to a Staco Maintenance Bypass Switch, refer to the manual for that product for proper operation. The MBS is equipped with a label that describes common transfer operations and a brief summary is provided below. Bypass switches provided by others are not recommended as they are not equipped with the proper interlocks to prevent backfeed, a hazardous condition that can be lethal to service personnel. Use of a non-Staco bypass switch may void the UPS product warranty.

The normal mode of operation (i.e. not bypass) requires that switches 1 and 3 in the MBS are closed. The UPS should be operating in this state. To transfer operation of the load to Maintenance Bypass mode, first perform a manual transfer to bypass per the procedure above. Verify that the mimic display changes to show that the load is now connected to the bypass line. Close Switch 2 in the MBS, then open Switch 3. Turn off the UPS, if desired,, then open Switch 1.

To return from Maintenance Bypass to Normal mode, close Switch 1 and start the UPS, Select manual Transfer to Bypass mode. Verify that the UPS is running and that the mimic diagram shows that the output is being supplied from the bypass line. Close Switch 3, then open Switch 2. Select Automatic Transfer to Inverter per the procedure below.

If the UPS fails to start and it is desired to get power to the load, open Switches 1 and 3 on the MBS, then close Switch 2. The load is now powered from the bypass, Note that the UPS logic is not involved in the decision to apply bypass power to the load, so there is no assurance that the bypass source is suitable for powering the load. This procedure is performed at the user's risk. Also note that the UPS will not start when the bypass source is out of specification.

Automatic Transfer To Bypass

The static switch will automatically transfer the load to bypass if the bypass input is qualified and one of the following conditions applies:

1. Initial start-up of UPS.
2. The inverter is unable to support the load due to a) failure, b) overload, c) battery reaches end of discharge voltage threshold.
3. Loss of output voltage is detected.

Automatic Transfer To Inverter

The static switch will automatically transfer the load to inverter if all of the following conditions are true:

1. The inverter has been started and is running normally.
2. The inverter is phase-locked to the bypass input.
3. There was no manual transfer to bypass.
4. There is no overload present.
5. There have not been more than three overload-caused transfers to bypass in a one hour period.

OverLoad

Inverter

Load	Time Supported
100%	Continuous
110%	2 Minutes
125%	30 Seconds

When the overload limits are exceeded while running on inverter, an automatic transfer to bypass occurs. When the overload clears, an automatic transfer to inverter occurs, unless there have been three overloads within one hour. Inverter overload performance is not guaranteed while running on battery.

Bypass

Load	Time Supported
110%	Continuous
125%	2 Minutes
150%	10 Seconds
700%	5 Cycles

When the overload limits are exceeded while on bypass, the static switch will turn off. Note that external circuit protection devices may operate during overload conditions.

Rectifier

The rectifier is microprocessor controlled using algorithms that limit the input current to levels that protect the rectifier components. If the inverter requires more current than the rectifier can provide, the battery will supply current as needed. Thus, the rectifier will supply as much energy as is available from the rectifier input. At 80% input voltage, the rectifier can support the rated inverter load, but does not have any extra capacity to charge the battery. At higher line voltages, there is enough capacity to charge the battery while supporting rated load.

The rectifier uses an advanced high frequency Pulse Width Modulated design that presents low current distortion to the input power source. Its high power factor means that maximum power is obtained for a given input current.

SECTION 8

Battery Removal, Installation, and Service

The batteries must only be serviced by authorized service personnel.

Before any battery service is attempted, the batteries must be disconnected by unplugging the cables to the battery trays. Before unplugging the cables, the connections should be marked in a way that no confusion will exist when it is time to reconnect the cables. The batteries are mounted in slide out trays that permit access to the battery to battery connections when the trays are withdrawn from the cabinet.



To service the battery trays, they must be removed from the cabinet by a fork lift. The 3 bus bars at the back of the tray, as shown in figure 15, must be removed before servicing or replacing the batteries.

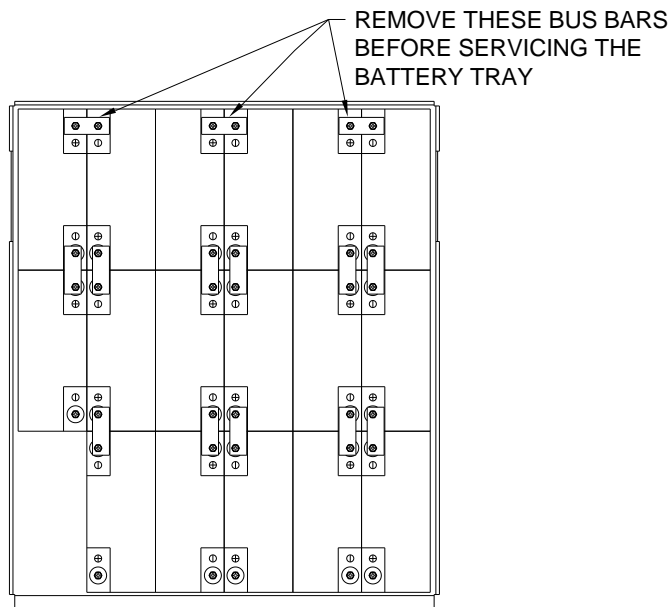

Figure 15-Battery Tray

If batteries are being replaced, only use the same manufacturer and battery type and rating as the battery removed.

It is very important that only one tray at a time be extended from the cabinet. If more than one tray is extended, the cabinet can become unstable and topple over.

After each tray is installed or serviced, it must be fully inserted and secured using the supplied threaded fasteners before attempting to install or service another tray.

If the trays are to be removed, always remove the highest tray first. The battery trays are very heavy and it will be necessary to use a lifting device to support the trays as they are removed. When the trays are to be reinstalled, use the procedure in the following paragraph.

If the UPS was shipped with no batteries installed, batteries may be installed at a later time using only those battery types shown in the **REPLACEMENT BATTERY** table under UPS Maintenance. **A Staco battery string consists of two (2) battery trays, Staco part number 812-1355-S; consisting of 17 batteries each. 220/127V models use Staco part number 812-1359-S trays; consisting of 18 batteries each.** First, verify that the cabinet is equipped with shelves to receive the battery trays. If this is not the case, contact the factory for assistance. The battery trays are very heavy and it will be necessary to use a lifting device to support the trays as they are installed. Do not take away the external support until the extension limit tabs on the upper sides of the battery tray are inserted past the notches on the upper edge of the battery shelf (see figure 16). Always install the lowest battery tray first (see figure 17). After it is inserted fully into the support shelf, secure the tray with the supplied threaded fasteners. After all of the trays are reinstalled and secured, reconnect the cables using the markings as a guide. If this is a new battery installation, connect the battery cables using the procedure in the following paragraphs.

WARNING

Never connect the two cables from a battery tray or from a battery string (two trays) together as severe damage will occur, resulting in fire and/or injury. Battery connections should only be made by a person wearing eye protection. It is advised that eye wash be available. If there are any doubts about the proper connections, do not proceed.

For a two tray (single string) battery, connect the blue plug from the upper tray to the blue plug from the lower tray. Connect the black plug from the lower tray and the red plug from the upper tray that are joined together, to the joined black plug from the electronics section and the red plug from the battery fuse on the front of the electronics section (see figure 10). For a four tray (double string) battery, connect the upper two trays as described above. Then, take the joined black plug from the lowest tray and the red plug from the tray above the lowest one and insert them into the second dc input connector, making sure that the red plug from the battery tray goes to the red side of the dc input connector and that the black plug from the battery tray goes to the black side of the dc input connector. Finally, connect the blue plug from the tray above the lowest tray to the blue plug of the lowest tray.

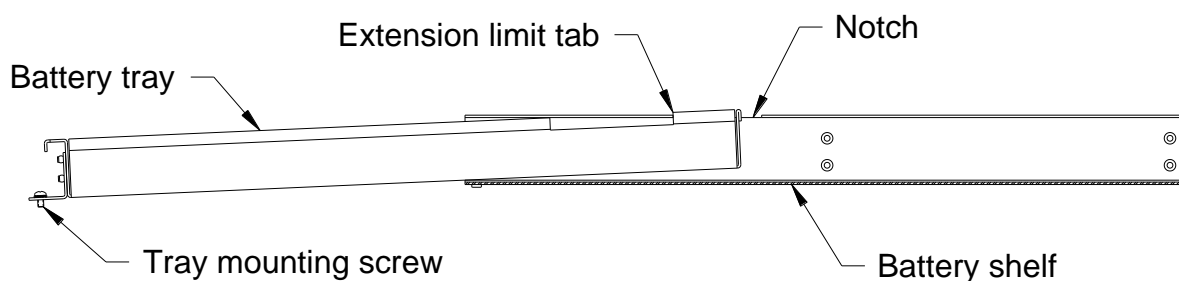

Cutaway side view of battery tray
batteries not shown for clarity

Figure 16-Battery Tray

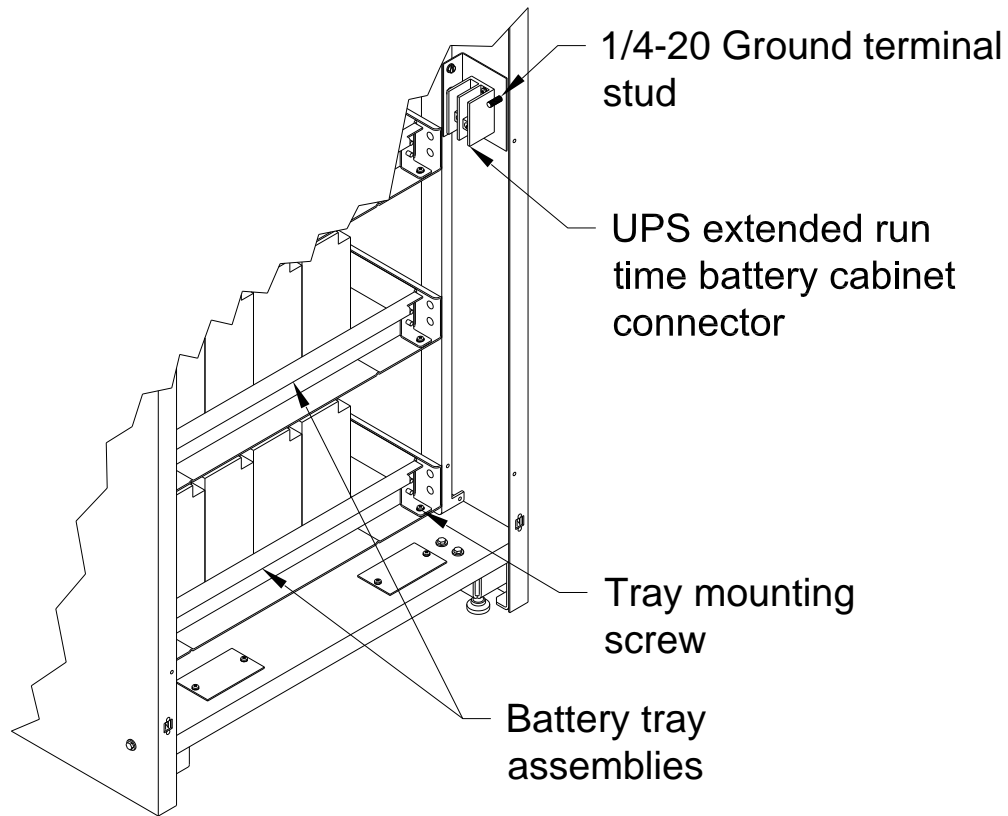

Figure 17-Battery Installation

EXTENDED RUN TIME BATTERY TERMINAL TIGHTENING TORQUE	
#2-#3 AWG	50 inch-pounds
#4-#6 AWG	45 inch-pounds

Note: Size wire per local codes, #6 AWG 75°C copper wire minimum to #2 AWG maximum.

GROUND STUD TIGHTENING TORQUE
55 INCH-POUNDS

A 7/16" wrench is needed to connect to the ground stud.

Special Considerations for Connection Batteries to the FirstLine UPS, including Extended Run Time Battery Cabinets

It is never safe to work within either the UPS or the extended battery cabinet while the UPS is powered. The battery produces a lethal voltage whether or not the UPS is powered or running. Always work with extreme caution. No service work should be performed unless the personnel are properly trained and appropriate tools and equipment are available.

All batteries must be connected to the UPS prior to starting the rectifier. The rectifier runs whenever the UPS is on. If a battery is disconnected while the rectifier is running (for example, if the optional breaker on an extended battery cabinet is opened while the UPS is running), it must not be closed without first stopping the rectifier. This same precaution applies to opening the external user supplied battery disconnect device. If one is present. Connecting a battery while the rectifier is running will cause equipment damage that is not covered by the equipment warranty. See the procedure, below, for stopping the rectifier.

It is essential that the Extended Battery Cabinet be connected with the proper polarity. Reverse polarity will cause equipment damage that is not covered by the equipment warranty. There is a polarity verification procedure, below, that will help to prevent mishaps. Wires should be marked using colored tape to avoid confusion. Note that the terminal block in the UPS and the terminal blocks in the Extended Battery Cabinet all use the left-hand terminal for the positive connection and the right-hand terminal for the negative connection.

Before connecting the wires between the UPS and the Extended Battery Cabinet, the UPS must be powered down, the front outer panel must be removed, the front inner safety panel must be removed, and all internal batteries must be disconnected by unplugging the red and black battery plug from the DC input plug for each battery string. Most units have one battery string, but a second string is an option in the tall cabinet version. On the Extended Battery Cabinet, the front outer panel must be removed, the front inner safety panel must be removed, and all internal batteries must be disconnected by unplugging the red and black battery plugs between each battery string and the plug pair between the lowest battery string and the input/output panel. Connect the three wires (positive, negative, and ground) to the external battery terminal block and the grounding stud at the UPS end. Connect the Extended Battery Cabinet end of the three wires to the terminal block on the left and to the ground stud. The positive wire goes to the left-hand terminal and the negative wire goes to the right-hand terminal. If additional cabinets are to be added, run the three wires from the first cabinet to the second using the right-hand terminal block in the first cabinet and the left-hand terminal block in the second cabinet. If a third cabinet is present, run the three wires from the second cabinet to the third using the right-hand terminal block in the second cabinet and the left-hand terminal block in the third cabinet.

Polarity Verification Procedure

Check to make sure that all wiring is proper and secure and that all personnel are clear of hazardous circuits.

For this procedure, the UPS should be off with no power applied.

If the UPS has an internal battery, connect it to the DC input connector. If there is an external user supplied battery disconnect device, it should be closed. At the external battery cabinet, measure the dc voltage from the left-hand fuse (positive lead of meter) to the right-hand fuse (negative lead of meter). The voltage measured should be positive. If not, the polarity of the connections is not correct. (The voltage measured during this procedure should be in the range of 400 to 470 Vdc, depending on the state of charge of the battery). Repeat this measurement for the other Extended Battery Cabinets, if present. The battery plugs for all strings in the Extended Battery Cabinet(s) can be connected at this time.

If the UPS does not have an internal battery, start by connecting the plug from the lowest battery string in the Extended Battery Cabinet to the plug from the input/output panel. If there is an external user supplied battery disconnect device, it should be closed. Measure the voltage at the external battery terminal block in the UPS with the positive lead of the meter on the left-hand terminal and the negative lead of the meter on the right-hand terminal. The voltage measured should be positive. If not, the polarity of the connections is not correct. If there is a second Extended Battery Cabinet, measure the dc voltage in that cabinet from the left-hand fuse (positive lead of meter) to the right-hand fuse (negative lead of meter). The voltage measured should be positive. If not, the polarity of the connections is not correct. Repeat this measurement for the third Extended Battery Cabinet, if present. The battery plugs for all strings in the Extended Battery Cabinet(s) can be connected at this time.

Stopping the Rectifier in the UPS

Before connecting any batteries to the UPS, the rectifier must be stopped. The rectifier is stopped whenever the UPS is OFF. The batteries are disconnected whenever the optional disconnect breaker(s) in the Extended Battery Cabinet(s) is (are) open, or whenever the external user supplied battery disconnect device is open. If the Extended Battery Cabinet(s) is(are) equipped with the optional disconnect breaker, it is possible for a breaker to be opened during operation, which requires that the rectifier be stopped before closing the breaker. If the external user supplied battery disconnect device is opened during operation, it is necessary to stop the rectifier before closing the device. All breakers should be closed when the UPS is started. Generally, the only reason to open any of the battery disconnect devices is to perform service, which requires that the UPS be turned off. It is best to close the disconnect devices before starting the UPS and leave them closed during operation. In the event of an emergency condition that requires opening a disconnect device, it will be necessary to stop the rectifier in order to restore the system to normal configuration.

The simplest way to stop the rectifier is to turn off the UPS by pressing the power ("line-circle") button on the front panel. This will remove power from the load. Once the battery breaker(s) has (have) been closed, the UPS can be restarted by pressing the power button.

If the UPS is connected to the load using a Maintenance Bypass Switch (MBS), the load can be maintained when the UPS is turned OFF.

To transfer to MBS:

1. Verify that the bypass source is available (Bypass lamp on UPS mimic display is green).
2. Perform a manual transfer to bypass mode on the UPS by pressing and holding the ESC key while simultaneously pressing the UP-ARROW key.
3. Verify that the UPS output is ON BYPASS by observing that the lamp associated with the bypass line at the static switch block on the mimic display is green and that the lamp associated with the inverter is not lit.
4. Operate the MBS to put it in bypass mode.

It is now safe to turn off the UPS and close the battery breaker(s). Restart the UPS. To transfer back to normal mode:

1. Verify that the UPS is still ON BYPASS by observing the mimic display. If not, perform a manual transfer to bypass as described, above.
2. Operate the MBS to put it in normal mode.
3. Enable automatic transfer by pressing and holding the ESC key while simultaneously pressing the DOWN-ARROW key. After a few seconds, the mimic display should show that the static switch has transferred the load to inverter.

UPS Maintenance

The FirstLine UPS is designed to be virtually user maintenance free, requiring only the occasional wipe with a damp cloth or non-abrasive cleaner.

Spare kits are available for the FirstLine UPS series, please contact Staco Energy Products Co. service center for details.

For maximum availability of the UPS, the components that are subject to wear should be replaced as part of a comprehensive preventive maintenance program:

RECOMMENDED REPLACEMENT INTERVALS	
Dc Filter Capacitors	5 years
AC Filter Capacitors	5 years
Fans	2 years
Rectifier Chokes	10 years
Batteries	2 to 5 years ¹

REPLACEMENT BATTERY		
Manufacturer	Cat. Number	Quantity Required²
China Storage Battery	HR1290W	34 per string

All servicing should be performed by qualified service personnel.

¹ Battery life is highly dependent on the ambient temperature and the number and depth of discharge cycles. A discharged battery should be recharged as soon as possible. If the battery is left in a discharged state, irreversible sulfation occurs, reducing the capacity (run-time) of the battery.

² Some model configurations will use 36 batteries per string. 36 battery models are not part of the UL listing.

Battery Fuse Replacement

If an input line voltage transient well in excess of the UPS rating occurs while the UPS is running on battery, it is possible for the battery fuse to clear open. The symptom of an open battery fuse is the same as a disconnected battery: after the UPS is started, the battery lamp on the mimic display glows red. Prior to starting the UPS, the front panel display can be used to read the battery voltage. If the voltage is less than 380 Vdc, the UPS will determine that there is no useable battery present. Possible causes include a blown fuse, a disconnected battery, and a defective battery.

There are two battery fuses. Either one could be open, so the safe action is to replace both of them. The following procedure should only be performed by trained, authorized service personnel. For continued safety, fuses must be replaced by parts of proper rating.

1. Turn off the UPS. If an MBS is present, the load can be maintained by transferring to Maintenance Bypass mode prior to turning off the UPS.
2. Remove the utility ac power from the input of the UPS.
3. If any external battery cabinets are present, disconnect the batteries in all of them. If the external battery cabinet is equipped with the optional circuit breaker, it is only necessary to open (turn off) this breaker which is accessible by removing the front cover of the cabinet. If not equipped with this breaker, it is necessary to remove the inner panel and unplug the red and black connectors.
4. Remove the outer panel from the UPS by pulling the top away from the UPS and lifting the panel.
5. Remove the inner panel by removing the screws around the periphery of the panel and from the four holes next to the fans. The panel can be lifted off, but it is attached to the UPS by a ground wire that will limit movement.
6. Unplug the battery by disconnecting the red and black plugs. If the UPS is in the tall cabinet and has four trays of batteries, also disconnect the second battery connector.
7. For assured safety, measure the dc voltage across the terminal block for the external battery. If the voltage is more than 10 Vdc, double check that all batteries are disconnected.
8. Also measure the dc voltage between the "-" (minus) terminal on the external battery connector and the four connections on the two dc fuses. One dc fuse is just below the fans. The other is on the shelf below and to the right of the fans. If the dc voltage is greater than 40 volts, there must be at least one battery still connected.
9. If voltage measurements are not possible, visually verify that all batteries are disconnected and wait at least 5 minutes for capacitors to discharge.
10. The fuses can be replaced by loosening the nuts that hold the fuses in place using a 13 mm wrench, slipping out the old fuse, and slipping in the new one. Be sure that the washers are above the tabs on the fuses. Re-tighten the nuts.

11. Reconnect the internal battery(s) in the UPS.
12. Replace the inner panel.
13. In there is an external battery, reconnect all of the batteries and replace the inner panel. If there is the optional breaker, simply close the breaker to connect the battery.
14. Replace the outer panels on the UPS and the battery cabinet (if present).
15. Reapply utility ac power to the UPS.
16. Start the UPS.
17. Verify that the battery lamp glows green. Look at the battery parameter screen (Down, Right, Right, Right) and verify that the battery current is positive (charging) or that it is near zero and the voltage is 460 - 470 Vdc.

SECTION 9

Optional FirstLine Extended Run Time Battery Cabinet

The FirstLine extended run time battery cabinet is used in conjunction with the FirstLine uninterruptible power supply (UPS) to prevent loss of valuable electronic information and minimize equipment downtime. During brownouts, blackouts, and other power interruptions, batteries provide emergency power to safeguard operation.

Figure 18 shows the FirstLine extended run time battery cabinet, which can be outfitted with one, two, or three strings of batteries and with or without a circuit breaker. Connections in the UPS for the extended run time battery cabinet are shown in figure 16. For installation and maintenance instructions see user's manual no. 003-2324.

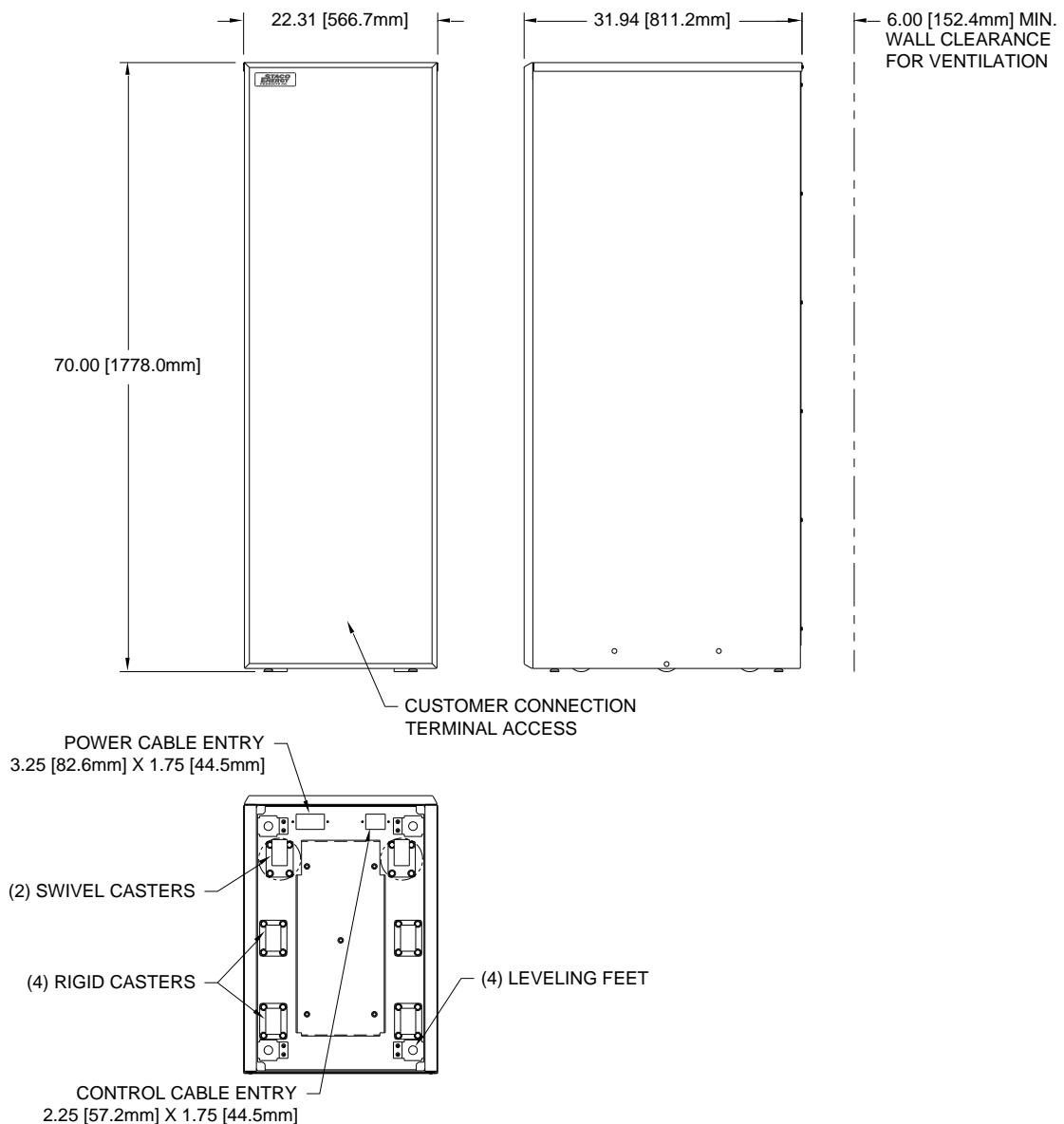

Figure 18-The FirstLine Extended Run Time Battery Cabinet

SECTION 10

FirstLine UPS Technical Specifications

UPS Rating kVA/Kw	25/20	30/24	37.5/30	
Input				
Voltage	208Y, 220Y or 480 Three Phase 4 wire plus ground - Optional 3 wire delta ISO available			
Range	+10% -20% From Nominal (-15% For Battery Recharge) +10% -10% from nominal to start UPS			
Frequency	57-63 Hz			
Power Factor	> 0.98 At Full Load			
Current Distortion (THD)	< 5% At Full Load			
Input Current	Nominal:	62	75	94
(208V rating, non-isolated)	Maximum:	83	105	128
Input Current Inrush	Walk-In from 25% maximum to 100% full load rating in 5 seconds			
Output				
Voltage	208Y,220Y, 480 Three Phase 4 wire plus ground			
Frequency (free running on battery)	60 Hz +/- 0.01%			
Voltage Regulation	+/- 1% balanced load, +/- 3% with 100% unbalanced load			
Voltage Transient Response	< 5% voltage change for 100% load step with recovery to less than 2% in less than 1 cycle			
Voltage Distortion THD	< 2% with linear load, < 5% with 100% non-linear load			
Inverter Overload	100% continuous, 125% for 2 minutes, 150% for 1 second			
Bypass Overload	110% continuous, 125% for 2 minutes, 150% for 10 seconds, 700% for 5 cycles			
Output Current (Amp's at 208V)	70/55	83/66	104/83	
Heat Rejection (BTU/Hr)	7583	9100	8900	
Battery Run Time-Minutes³				
One Internal Battery String	10	8	5	
Extended Run Time - Two Internal Battery Strings	27	22	16	
Environmental				
Altitude	Derate load capability above 1000 meters 1% per 100 meters,			
Operating Temperature	40° C. Maximum.			
Dimensions and Weights (mm) (Kg)				
UPS-Standard	23.0 in (284.2) W x 32.38 in (822.45) D x 70.0 in (1778) H		1253 lbs (568)	
Two Internal Battery Strings	23.0 in (284.2) W x 32.38 in (822.45) D x 70.0 in (1778) H		1765 lbs (801)	
One Battery String	23.0 in (284.2) W x 32.38 in (822.45) D x 70.0 in (1778) H		1855 lbs (841)	
480/480 I/O				
Standards				
208V and 480V Models	UL listed to 1778, CUL to CSA C22.2, NEMA PE-1, ASME, ASA-C-39.1-1984, FCC Part 15 Subpart J Class B, NEC, OSHA, IEEE587, ANSI C 62.41-1980, ISO9000			



220V models are not listed to UL, CUL, or CSA Standards.

³ Run time is approximate and depends on the battery state of charge, age, operating temperature and other conditions.

