

CurrentGuard™ 200 Plus

Extra Features



SYSTEM FEATURES

- Listed to UL 1449 3rd Edition for Type 1 and Type 2 SPD applications
- Innovative Z-Path System™ ensures equal current sharing, increased reliability and maximum performance
- **Individually fused MOVs provide superior protection and continuous operation**
- 200kAIC short circuit current rating allows direct bus connection without the need of an upstream over-current protection device
- **Includes best-in-class UL 1283 enhanced EMI/RFI filter**
- All modes of protection (L-N, L-G, N-G & L-L)
- Form C contacts and audible alarm with silence button – standard
- **Surge event counter – standard**
- DTS-2 compatible for “pro-active” testing
- Ultra compact steel NEMA 4 enclosure makes installation flexible
- **15-Year standard product warranty**

MODEL NUMBER SCHEME

E.g. MODEL # **CGP 200 - 277/480-3GY - D**

A
B
C

A – SURGE RATING (Must Choose One)

60	60kA per mode
80	80kA per mode
100	100kA per mode
150	150kA per mode
200	200kA per mode

B – VOLTAGE (Must Choose One)

120/240-2G	120/240V, 1-Phase, 3-Wire + Ground
120/208-3GY	120/208V, 3-Phase WYE, 4-Wire + Ground
220/380-3GY	220/380V, 3-Phase WYE, 4-Wire + Ground
277/480-3GY	277/480V, 3-Phase WYE, 4-Wire + Ground
347/600-3GY	347/600V, 3-Phase WYE, 4-Wire + Ground
120/240-3GHD	120/240V, 3-Phase High-Leg DELTA, 4-Wire + Ground (B Phase must be 208V)
240-3DG	240V, 3-Phase DELTA, 3-Wire + Ground
380-3DG	380V, 3-Phase DELTA, 3-Wire + Ground
480-3DG	480V, 3-Phase DELTA, 3-Wire + Ground
600-3DG	600V, 3-Phase DELTA, 3-Wire + Ground

C - OPTIONS

	Leave Blank for no Disconnect
-D	For 200 kAIC External Disconnect

STAND-ALONE OPTIONS (To Be Ordered As A Separate Item)

DTS	DTS-2 Diagnostic Test Set
-----	---------------------------

PRODUCT SPECIFICATIONS

General Specifications

Maximum Surge Current Capacity:	200kA per mode; 400kA per phase
Nominal Discharge Surge Current In:	20kA
Repetitive Surge Current Rating:	6,500 impulses per mode based on actual test data (using ANSI/IEEE C62.41.1-2002 C3 combo. wave)
Product Design:	Hybrid parallel design with individual fused MOVs and UL 1283 EMI/RFI filter
Application:	ANSI/IEEE C62.41.1 Locations C, B & A Ideal for service entrance, distribution panels and motor control centers
Regulatory Listing:	UL 1449 3 rd Edition Type 1 and Type 2 SPD; UL 1283
Standard Warranty:	15-Year

Electrical Specifications

Operating Frequency:	47-63 Hz
Connection Method:	Parallel to electrical distribution system
Modes of Protection:	Discrete protection (L-N, L-G, N-G, & L-L)
Fault Rating (SCCR):	200kAIC – no upstream over-current protection device (breaker or fuse) required
Response Time:	Less than 0.5 nanoseconds
Standard Monitoring:	Status indicator lights (one per phase) Service indicator light Form C contacts (NO/NC) Audible alarm with silence button Surge counter

EMI / RFI Filter Attenuation – Mil Standard 220B

Up to 33 dB from 10 KHz to 100 MHz



CurrentGuard™ 200 Plus

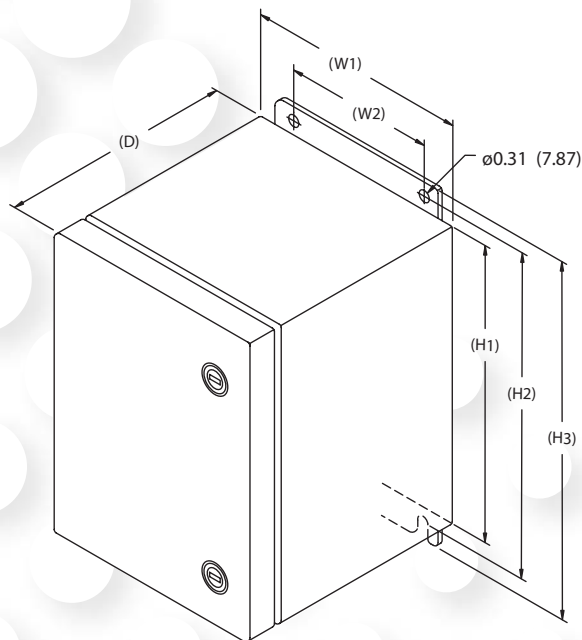

DIMENSIONAL SPECIFICATIONS

Dim	CGP200	
H1	14.00	(355.6)
H2	14.75	(374.7)
H3	15.50	(393.7)
W1	12.00	(304.8)
W2	10.00	(254.0)
D	6.20	(157.5)

All measurements in inches (mm)

MECHANICAL SPECIFICATIONS

Enclosure Type:	Powder coated, impact-resistance steel, weather-proof NEMA 4
Installation Location:	Indoor or outdoor
Dimensions:	14"H x 12"W x 6"D
Connection Method:	Hard-wired via internal lugs #10AWG - #3 AWG
Mounting Method:	Dual mounting flanges
Operating Environment:	-40° C to +70° C (-40° F to +158° F) 5% - 95% non-condensing humidity
Weight:	40 lbs. (18.2 kg)

CURRENTGUARD 200 PLUS PERFORMANCE DATA

Model Number	CGP200-120/240-2G CGP200-120/208-3GY				CGP200-220/380-3GY CGP200-277/480-3GY				CGP200-347/600-3GY				CGP200-120/240-3GHD						CGP200-240-3GB		CGP200-380-3GB		CGP200-480-3GB		CGP200-600-3GB	
	System Voltage				System Voltage				System Voltage				System Voltage						System Voltage		System Voltage		System Voltage			
System Voltage	120/240V 120/208V				220/380V 277/480V				347/600V				120/240V						240V		380V 480V		600V			
Protection Mode	L-N	L-G	L-L	N-G	L-N	L-G	L-L	N-G	L-N	L-G	L-L	N-G	L-N	H-N	L-G	H-G	L-L	H-L	N-G	L-G	L-L	L-G	L-L	L-G	L-L	
MCOV	150	150	300	150	320	320	640	320	420	420	840	420	150	320	150	320	300	470	150	320	320	550	550	750	750	
B3 Ring Wave 6kV, 500A	420	480	610	340	660	750	960	720	715	829	1130	670	420	759	470	640	605	800	320	750	630	1050	860	1245	1060	
B3/C1 Combo Wave 6kV, 3kA	642	690	1010	620	910	1068	1700	974	1250	1340	2300	1230	642	910	690	1068	1010	1400	620	940	1020	1450	1670	1960	2260	
C3 Combo Wave 20kV, 10kA	1040	1300	1420	1240	1490	1830	2290	1690	1910	1960	2910	1880	1040	1490	1300	1830	1420	2050	1240	1650	1680	2160	2470	2760	2950	
UL 1449 3rd Edition 6kV, 3000A VPR	800	800	1200	800	1200	1200	1800	1200	1500	1500	2500	1500	800	1200	800	1200	1200	1500	800	1200	1200	1800	1800	2500	2500	

All CurrentGuard™ Plus systems measured limited voltages are peak values (±10%) measured from the zero reference point and are in compliance with test and evaluation procedures outlined in NEMA LS1-1992 (R2000), paragraphs 2.210 and 3.10.

Specifications subject to change without notice, refer to www.currenttechnology.com for latest revision.



5900 Eastport Boulevard Richmond, VA 23231-4453 USA
TEL: 804.236.3300 800.238.5000 FAX: 804.236.4047

Warranty Statement

Standard Warranty

Current Technology warrants that your Current Technology surge protective device (the "Product"), shall meet applicable industry standards and specifications and be free from defects in materials and/or workmanship. Should any failure of the Product to conform to this warranty appear within the standard warranty period, Current Technology shall either repair or replace the defective Product, or part thereof, upon return to Current Technology manufacturing facility in Richmond, Virginia with transportation charges pre-paid. The applicable warranty period is outlined below in the warranty period section.

MasterPlan® Extended Warranty

The warranty period is extended to twenty (20) years if the Product meets all of the following criteria:

- a) The product is purchased simultaneously with a Select 2 selenium-enhanced SL2-300, SL2-250 or SL2-200 suppression filter system and
- b) the product is installed simultaneously with a Select 2 selenium-enhanced SL2-300, SL2-250 or SL2-200 suppression filter system and
- c) the product is installed electrically downstream from a Select 2 selenium-enhanced SL2-300, SL2-250 or SL2-200 suppression filter system.

Current Technology shall have no liability under this warranty for any problems or defects directly or indirectly caused by misuse of the Product, alteration of the Product (including removal of any warning labels), accidents, or improper installation, application, operation, or repair of the Product.

The liability of Current Technology under this warranty is expressly limited to the replacement or repair of the defective part thereof, at Current Technology sole option.

IN NO EVENT SHALL CURRENT TECHNOLOGY BE LIABLE FOR SPECIAL, INCIDENTAL, OR CONSEQUENTIAL DAMAGES OF ANY KIND OR CHARACTER, NOR SHALL CURRENT TECHNOLOGY' LIABILITY EVER EXCEED THE PURCHASE PRICE PAID FOR SUCH DEFECTIVE PRODUCT.

This warranty is not transferable and may only be enforced by the sole purchaser. Claims under this warranty must be submitted to Current Technology within thirty (30) days of discovery of any Current Technology product defect.

WARRANTY PERIOD

	Standard	MasterPlan®
Select2	20 Years	—
Select Compact	15 Years	20 Years
HPI	20 Years	20 Years
TransGuard	15 Years	20 Years
CurrentGuard Plus	15 Years	20 Years
CurrentGuard	10 Years	20 Years
CurrentGuard Compact	10 Years	20 Years
Electronic Grade Panelboards		
EGPE2	10 Years	20 Years
TransEnd	5 Years	20 Years
LoadGuard	5 Years	20 Years
Monitoring & Diagnostic Tools	5 Years	20 Years



5900 EASTPORT BLVD.
 RICHMOND, VA 23231-4453
 TEL.: 804.236.3300 / 800.238.5000
 FAX: 804.236.4047
www.currenttechnology.com